

**NEO HC MONOBLOK SERİSİ**  
*NEO HC MONOBLOCK SERIES*

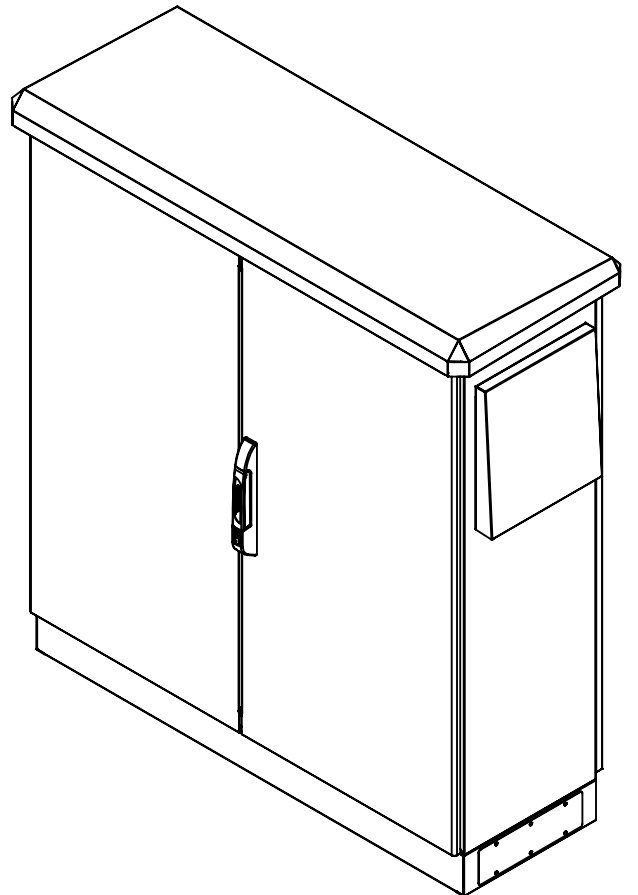

## NEO HC MONOBLOK SERİSİ

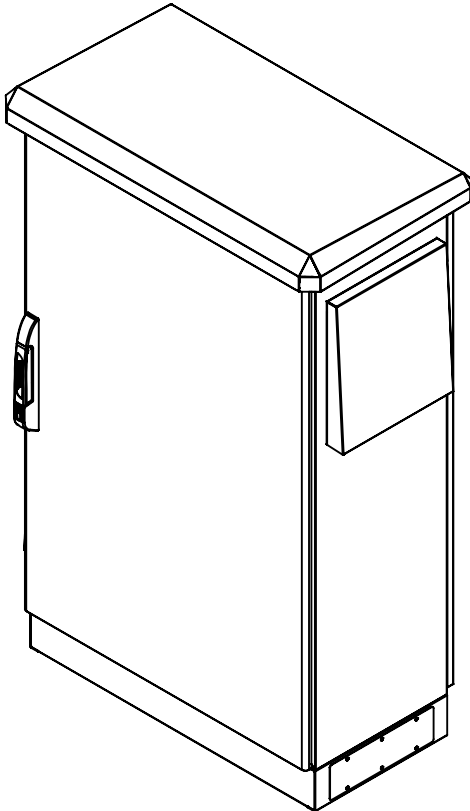
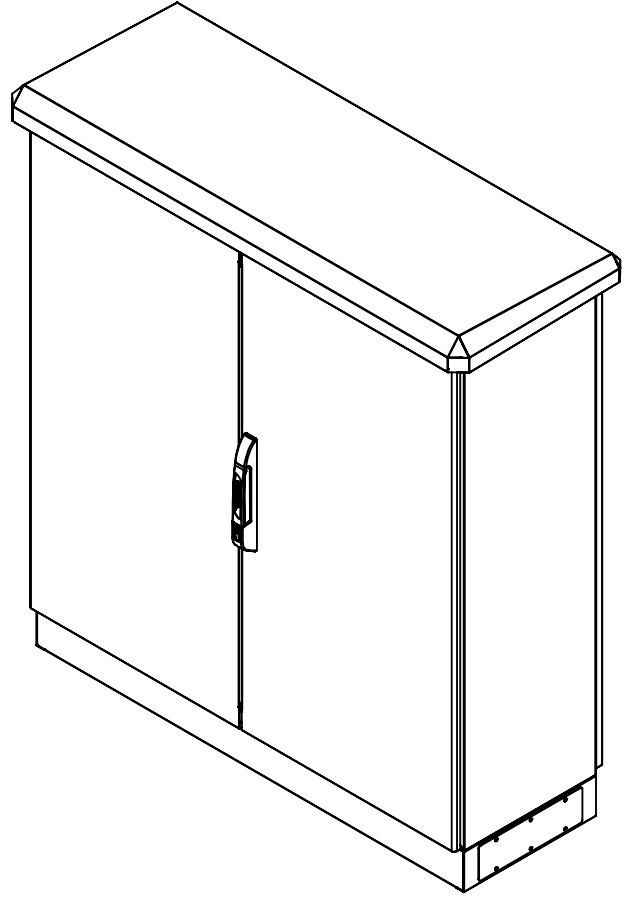
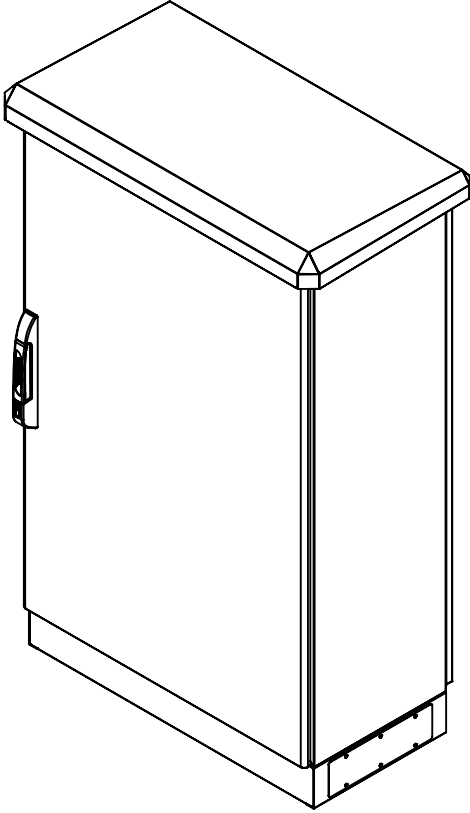
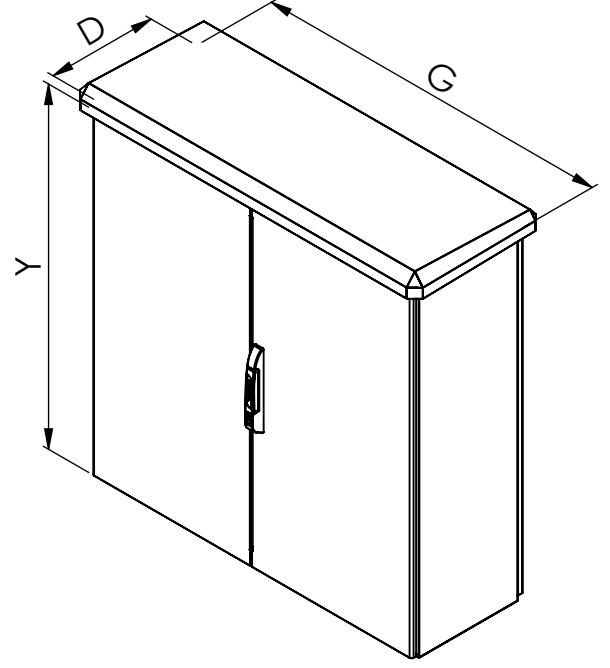
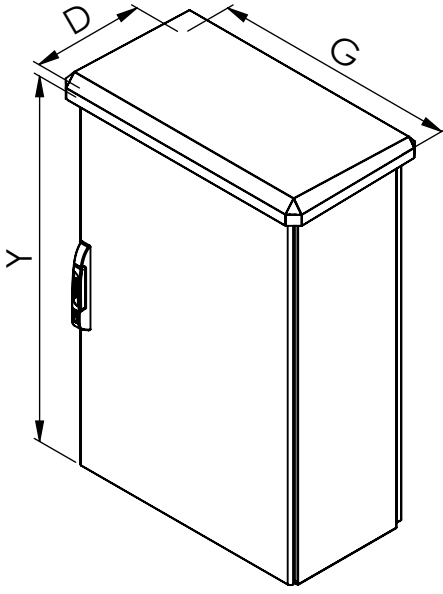

- 676.124.000** 600 G x 1200 Y x 400 D GÖVDE  
**676.126.000** 600 G x 1200 Y x 600 D GÖVDE  
**678.124.000** 800 G x 1200 Y x 400 D GÖVDE  
**678.126.000** 800 G x 1200 Y x 600 D GÖVDE

- 672.124.000** 1200 G x 1200 Y x 400 D GÖVDE  
**672.126.000** 1200 G x 1200 Y x 600 D GÖVDE

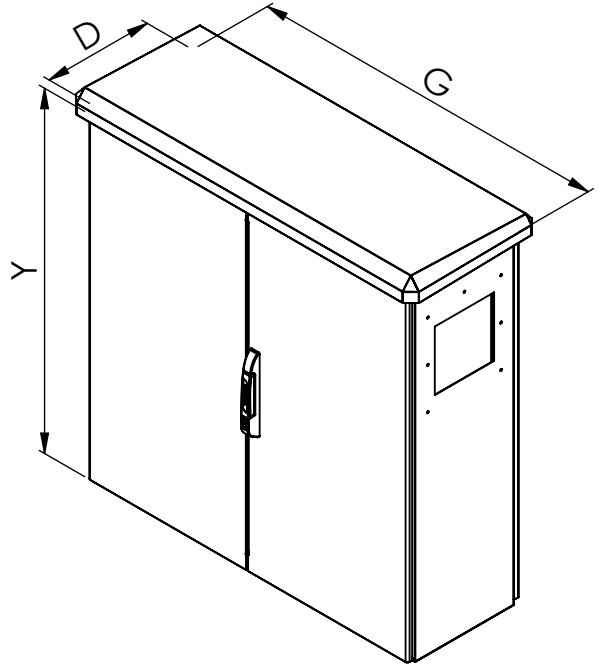
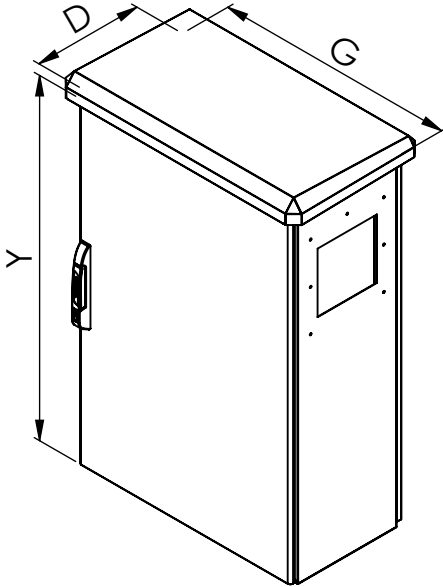

- 686.124.000** 600 G x 1200 Y x 400 D FİLTRELİ GÖVDE  
**686.126.000** 600 G x 1200 Y x 600 D FİLTRELİ GÖVDE  
**688.124.000** 800 G x 1200 Y x 400 D FİLTRELİ GÖVDE  
**688.126.000** 800 G x 1200 Y x 600 D FİLTRELİ GÖVDE

- 682.124.000** 1200 G x 1200 Y x 400 D FİLTRELİ GÖVDE  
**682.126.000** 1200 G x 1200 Y x 600 D FİLTRELİ GÖVDE

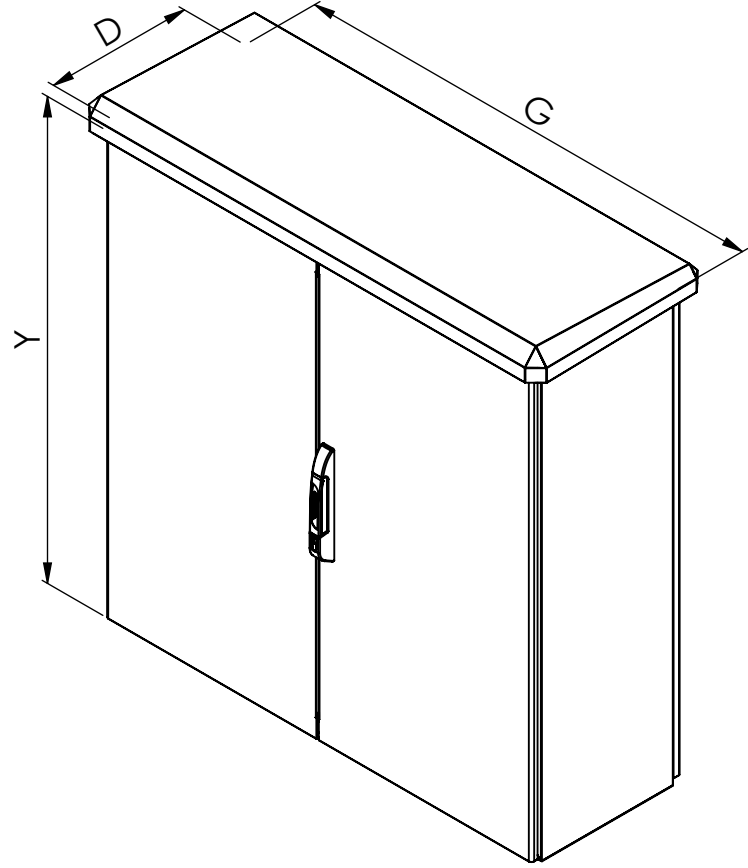
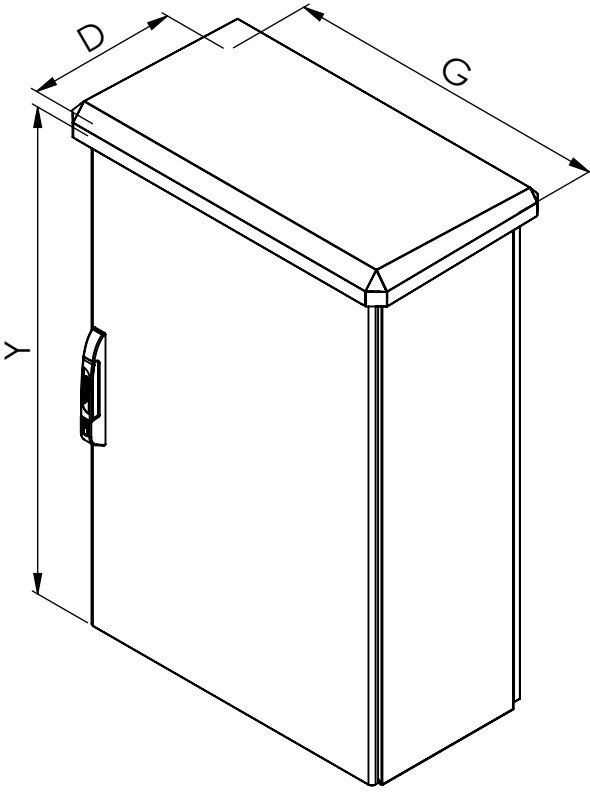

## NEO HC MONOBLOK SERİSİ

### ÜRÜN BİLGİSİ

SIRA	Ref.No:	PANO ÖLÇÜLERİ G x Y x D (mm)			SAC KALINLIKLARI (mm)					MONTAJ PLAKASI ÖLÇÜLERİ G x Y (mm)		MONTAJ PLAKASI	KAPI		
		*GENİŞLİK (mm)	*YÜKSEKLİK (mm)	*DERİNLİK (mm)	ANA GÖVDE (mm)	ÖN KAPI (mm)	ARKA KAPAK (mm)	ÇATI	MONTAJ PLAKASI (mm)	GENİŞLİK (mm)	YÜKSEKLİK (mm)	MON. PL. VAR/ YOK	KAPI TİPİ	KİLİT	MENTEŞE
		1	676.124.000	600	1200	400	1,5	1,5	1-1,2	1,5	2	288	1888	YOK	Tek
2	676.126.000	600	1200	600	1,5	1,5	1-1,2	1,5	2	288	1888	YOK	Tek	BAS-ÇEK KİLİT	4
3	678.124.000	800	1200	400	1,5	1,5	1-1,2	1,5	2	488	1088	YOK	Tek	BAS-ÇEK KİLİT	4
4	678.126.000	800	1200	600	1,5	1,5	1-1,2	1,5	2	488	1088	YOK	Tek	BAS-ÇEK KİLİT	4
5	672.124.000	1200	1200	400	1,5	1,5	1-1,2	1,5	3	488	1488	YOK	Çift	BAS-ÇEK KİLİT	4
6	672.126.000	1200	1200	600	1,5	1,5	1-1,2	1,5	3	488	1488	YOK	Çift	BAS-ÇEK KİLİT	4
7	686.124.000	600	1200	400	1,5	1,5	1-1,2	1,5	2	488	1888	YOK	Tek	BAS-ÇEK KİLİT	4
8	686.126.000	600	1200	600	1,5	1,5	1-1,2	1,5	2	488	1888	YOK	Tek	BAS-ÇEK KİLİT	4
9	688.124.000	800	1200	400	1,5	1,5	1-1,2	1,5	2	588	1888	YOK	Tek	BAS-ÇEK KİLİT	4
10	688.126.000	800	1200	600	1,5	1,5	1-1,2	1,5	2	588	1888	YOK	Tek	BAS-ÇEK KİLİT	4
11	682.124.000	1200	1200	400	1,5	1,5	1-1,2	1,5	3	688	1088	YOK	Çift	BAS-ÇEK KİLİT	4
12	682.126.000	1200	1200	600	1,5	1,5	1-1,2	1,5	3	688	1088	YOK	Çift	BAS-ÇEK KİLİT	4

**Malzeme** Ana Gövde, Çatı 1.5mm Galvaniz Sac; Ön Kapı 1.5mm DKP Sac; Arka Kapak 1-1.2mm DKP Sac  
Montaj Plakası 2mm - 3mm Galvaniz Sac

**Yüzey İşlem** Demir-fosfat + elektrostatik toz boya RAL 7035

**IK 10** Tek Kapılı, Çit Kapılı Pano

**IP Sınıfı** IEC ve EN 60529 Tek Kapılı, Çift Kapılı IP 55

**NEMA Sınıfı** Nema 3R

**Standartlar** IEC 62208 (Pano Standartları)

**Korozyon Sınıfı** TS EN ISO 12944-2' ye göre C3

**Garanti** KYT-72

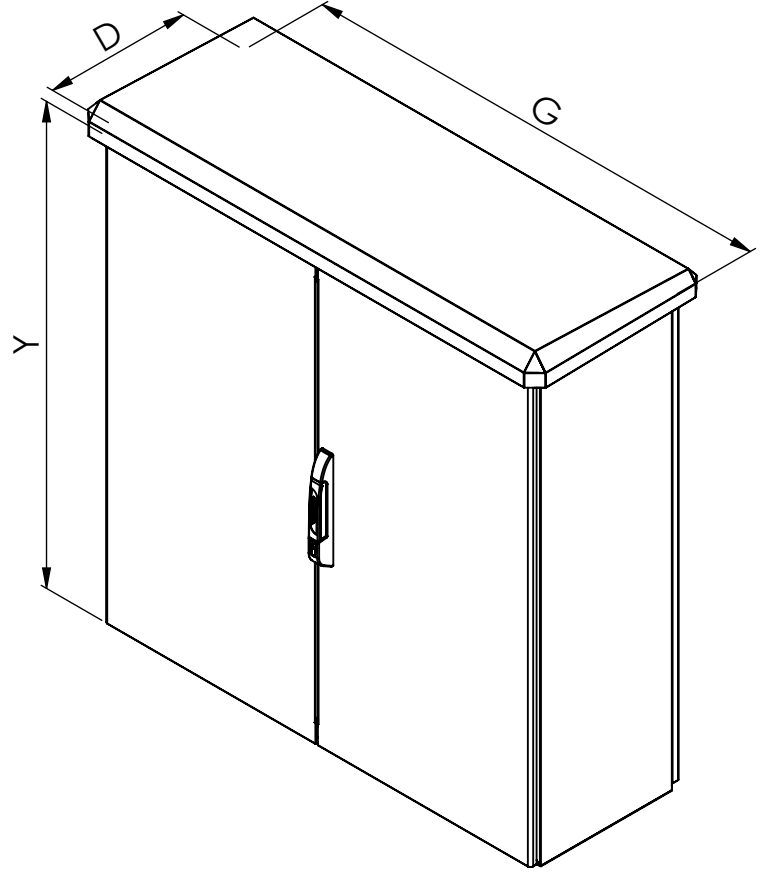
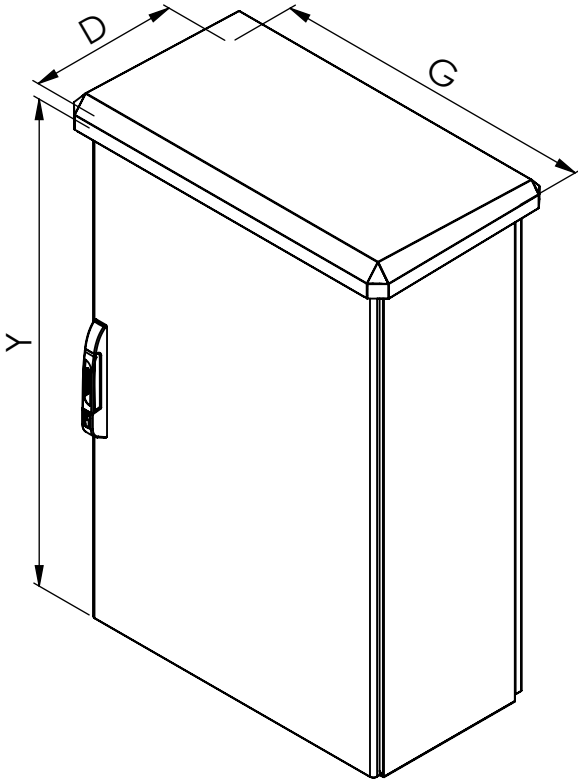

## NEO HC MB SERİSİ

### OPSİYONEL AKSESUARLAR

SIRA	Ref.No:	PANO ÖLÇÜLERİ G x Y x D (mm)			MONTAJ PLAKASI	MODÜLER BAZA G x Y x D (mm)				BLOK BAZA G x Y x D (mm)				TAŞIMA HALKASI (EYEBOLT KIT)
		*GENİŞLİK (mm)	*YÜKSEKLİK (mm)	*DERİNLİK (mm)		BAZA KÖŞESİ H(100)	**BAZA KÖŞESİ H(200)	BAZA ÖN-ARKA KAPAK (H100) (G)	BAZA YAN KAPAK (H100) (D)	BLOK BAZA (H100)	BLOK BAZA (H200)	BLOK BAZA YAN KAPAK (H100) (D)	BLOK BAZA YAN KAPAK (H200) (D)	
		1	676.124.000	600		1200	400	717.612	708.100	708.200	709.140	710.140	915.164	
2	676.126.000	600	1200	600	717.612	708.100	708.200	709.140	710.160	915.166	915.266	916.160	916.260	612.000
3	678.124.000	800	1200	400	717.812	708.100	708.200	709.160	710.140	915.184	915.284	916.140	916.240	612.000
4	678.126.000	800	1200	600	717.812	708.100	708.200	709.160	710.160	915.186	915.286	916.160	916.260	612.000
5	672.124.000	1200	1200	400	707.212	708.100	708.200	709.160	710.140	915.124	915.224	916.140	916.240	612.000
6	672.126.000	1200	1200	600	707.212	708.100	708.200	709.160	710.160	915.126	915.226	916.160	916.260	612.000
7	686.124.000	600	1200	400	717.612	708.100	708.200	709.160	710.140	915.164	915.264	916.140	916.240	612.000
8	686.126.000	600	1200	600	717.612	708.100	708.200	709.160	710.160	915.166	915.266	916.160	916.260	612.000
9	688.124.000	800	1200	400	717.812	708.100	708.200	709.170	710.140	915.184	915.284	916.140	916.240	612.000
10	688.126.000	800	1200	600	717.812	708.100	708.200	709.170	710.160	915.186	915.286	916.160	916.260	612.000
11	682.124.000	1200	1200	400	707.212	708.100	708.200	709.180	710.140	915.124	915.224	916.140	916.240	612.000
12	682.126.000	1200	1200	600	707.212	708.100	708.200	709.180	710.160	915.126	915.226	916.160	916.260	612.000

#### BİLGİ

\* Orijinal boyutlar için lütfen (2D çizim) elektronik kopyalarınızı kontrol edin.

\*\* 200mm baza köşesi, 100mm yükseklik baza kapakları ile kullanılmaktadır. Ön ve yan baza kapakları her biri iki adet sipariş edilmelidir.

## NEO HC MONOBLOCK SERIES

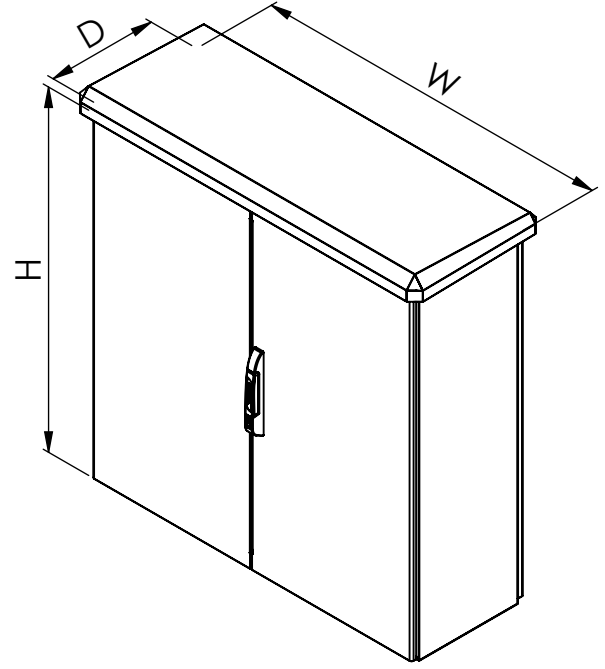
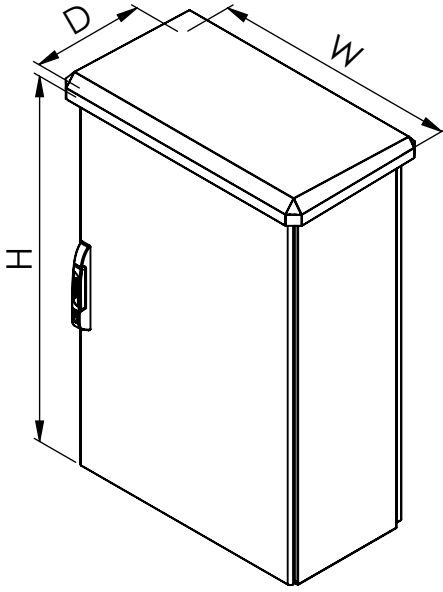

- 676.124.000** 600 W x 1200 H x 400 D BODY
- 676.126.000** 600 W x 1200 H x 600 D BODY
- 678.124.000** 800 W x 1200 H x 400 D BODY
- 678.126.000** 800 W x 1200 H x 600 D BODY

- 672.124.000** 1200 W x 1200 H x 400 D BODY
- 672.126.000** 1200 W x 1200 H x 600 D BODY

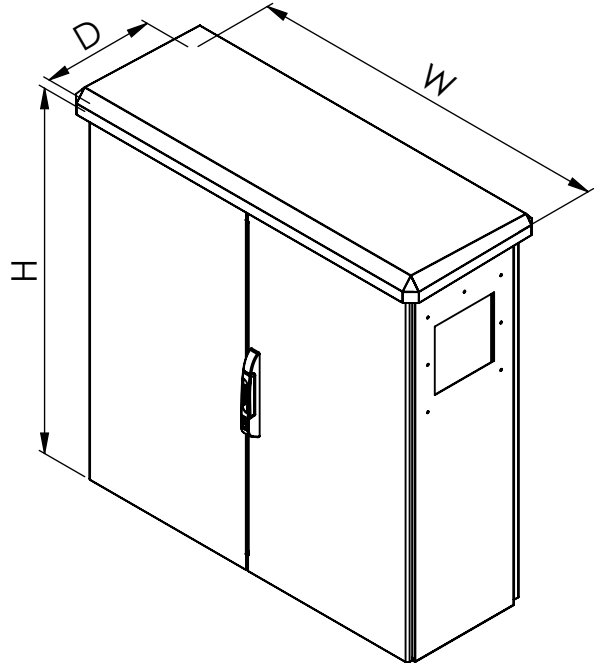
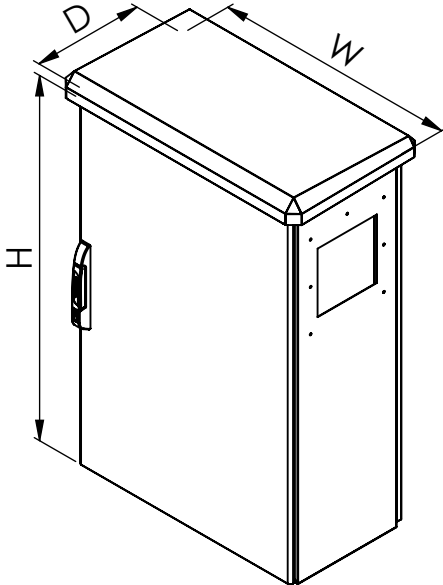

- 686.124.000** 600 W x 1200 H x 400 D BODY WITH CUT-OUTS
- 686.126.000** 600 W x 1200 H x 600 D BODY WITH CUT-OUTS
- 688.124.000** 800 W x 1200 H x 400 D BODY WITH CUT-OUTS
- 688.126.000** 800 W x 1200 H x 600 D BODY WITH CUT-OUTS

- 682.124.000** 1200 W x 1200 H x 400 D BODY WITH CUT-OUTS
- 682.126.000** 1200 W x 1200 H x 600 D BODY WITH CUT-OUTS

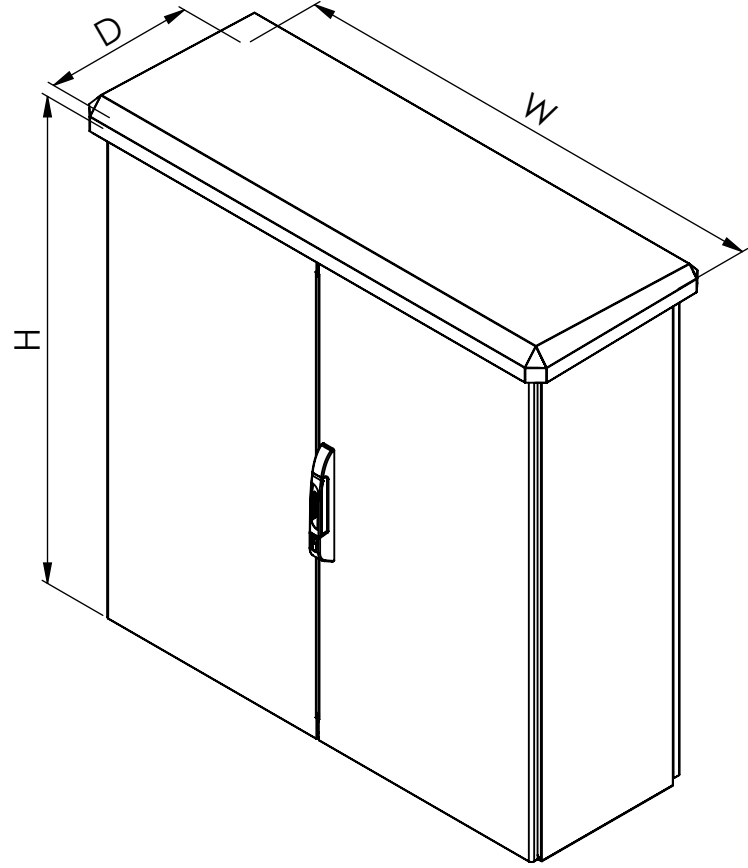
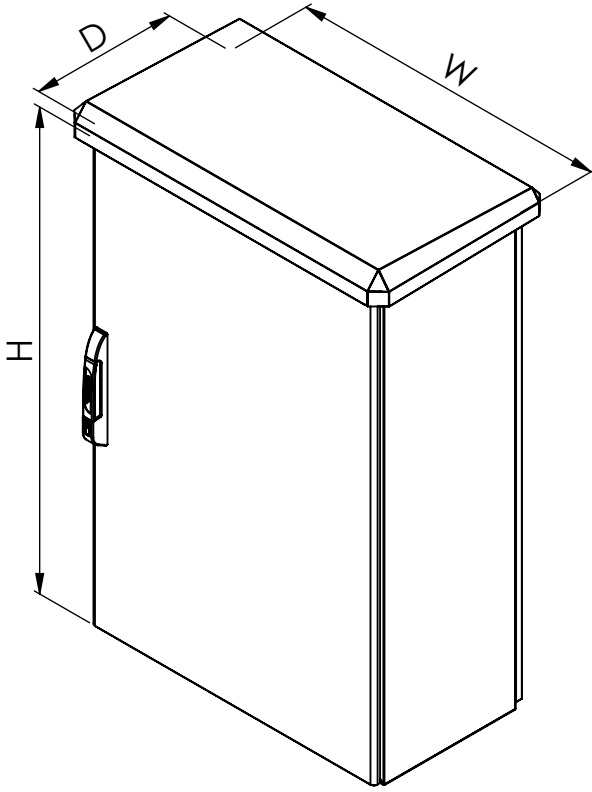

### NEO HC MB SERIES

#### PRODUCT INFORMATION

ITEM	Ref.No:	PRODUCT INFORMATION													
		ENCLOSURE DIMENSIONS W x H x D (mm)			SHEET THICKNESS (mm)					MOUNTING PLATE DIMENSINONS W x H (mm)		MOUNTING PLATE	DOOR		
		*WIDTH (mm)	*HEIGHT (mm)	*DEPTH (mm)	MAIN BODY (mm)	FRONT DOOR (mm)	REAR PANEL (mm)	ROOF (mm)	MOUNTING PLATE (mm)	WIDTH (mm)	HEIGHT (mm)	INC. W/O	DOOR TYPE	LOCK	HINGE
1	676.124.000	600	1200	400	1,5	1,5	1-1,2	1,5	2	288	1888	W/O	Single	PUSH-PULL LOCK	4
2	676.126.000	600	1200	600	1,5	1,5	1-1,2	1,5	2	288	1888	W/O	Single	PUSH-PULL LOCK	4
3	678.124.000	800	1200	400	1,5	1,5	1-1,2	1,5	2	488	1088	W/O	Single	PUSH-PULL LOCK	4
4	678.126.000	800	1200	600	1,5	1,5	1-1,2	1,5	2	488	1088	W/O	Single	PUSH-PULL LOCK	4
5	672.124.000	1200	1200	400	1,5	1,5	1-1,2	1,5	3	488	1488	W/O	Double	PUSH-PULL LOCK	4
6	672.126.000	1200	1200	600	1,5	1,5	1-1,2	1,5	3	488	1488	W/O	Double	PUSH-PULL LOCK	4
7	686.124.000	600	1200	400	1,5	1,5	1-1,2	1,5	2	488	1888	W/O	Single	PUSH-PULL LOCK	4
8	686.126.000	600	1200	600	1,5	1,5	1-1,2	1,5	2	488	1888	W/O	Single	PUSH-PULL LOCK	4
9	688.124.000	800	1200	400	1,5	1,5	1-1,2	1,5	2	588	1888	W/O	Single	PUSH-PULL LOCK	4
10	688.126.000	800	1200	600	1,5	1,5	1-1,2	1,5	2	588	1888	W/O	Single	PUSH-PULL LOCK	4
11	682.124.000	1200	1200	400	1,5	1,5	1-1,2	1,5	3	688	1088	W/O	Double	PUSH-PULL LOCK	4
12	682.126.000	1200	1200	600	1,5	1,5	1-1,2	1,5	3	688	1088	W/O	Double	PUSH-PULL LOCK	4

**Material** Main Body, Roof 1,5mm Galvanized sheet; Front Door 1,5mm Mild Steel; Rear Panel 1-1,2mm Mild Steel; Mounting Plate 2mm - 3mm Galvanized Sheet

**Surface Finishing** Iron phosphare + electrostatic powder coating RAL 7035

**IK 10** Single Door, Double Door

**IP Class** IEC and EN 60529 Single Door, Double Door IP 55

**NEMA Class** Nema 3R

**Standarts** IEC 62208 (Enclosure Standarts)

**Corrosion Class** C3 according to TS EN ISO 12944-2

**Guarantee** KYT-72

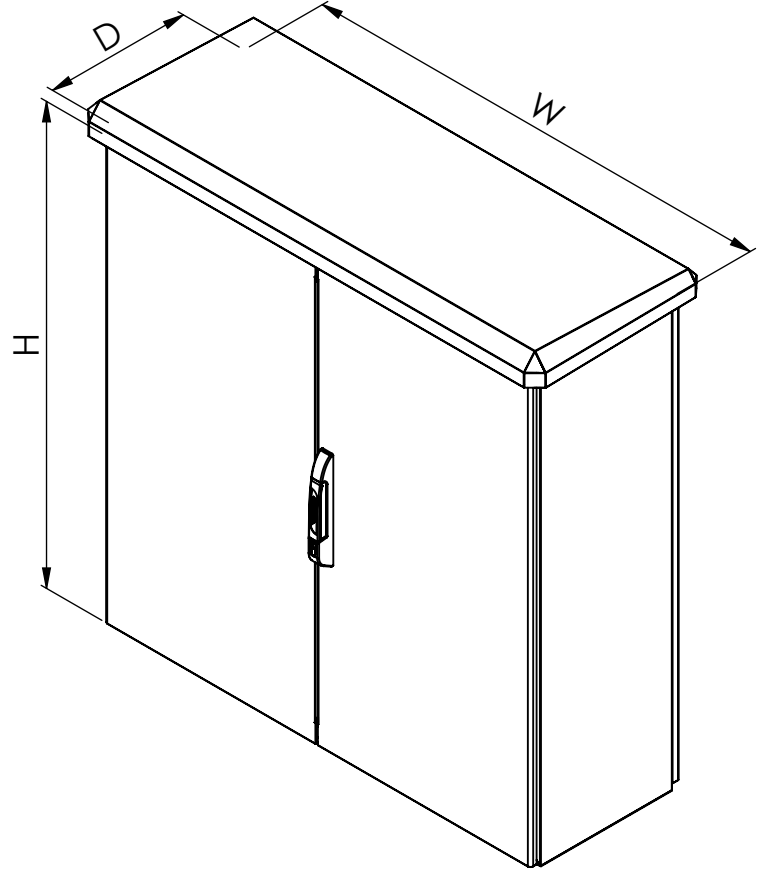
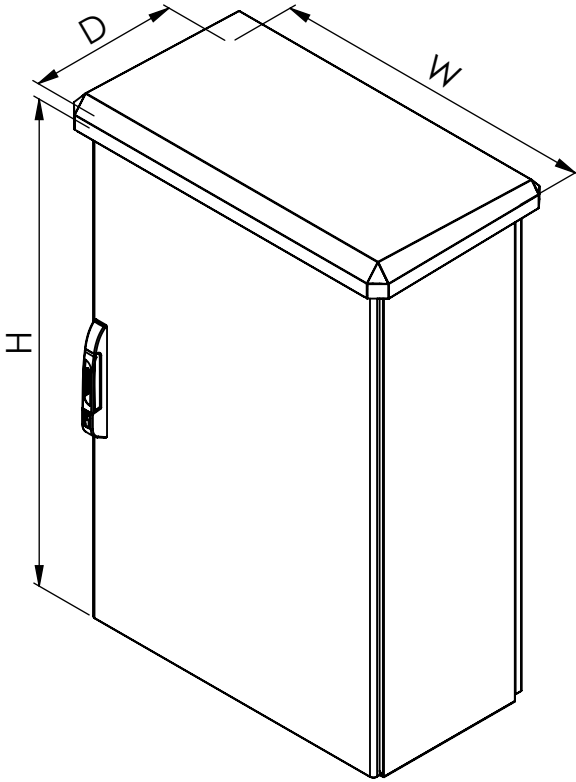

## NEO HC MB SERIES

### OPTIONAL INFORMATION

ITEM	Ref.No:	ENCLOSURE DIMENSIONS W x H x D (mm)			MOUNTING PLATE	MODULAR PLINTH W x H x D (mm)				BLOCK PLINTH W x H x D (mm)				EYEBOLT KIT
		*WIDTH (mm)	*HEIGHT (mm)	*DEPTH (mm)		PLINTH CORNER H(100)	**PLINTH CORNER H(200)	PLINTH FRONT COVER (H100) (W)	PLINTH SIDE COVER (H100) (D)	BLOCK PLINTH (H100)	BLOCK PLINTH (H200)	BLOCK PLINTH SIDE COVER (H100) (D)	BLOCK PLINTH SIDE COVER (H200) (D)	
		1	676.124.000	600		1200	400	717.612	708.100	708.200	709.140	710.140	915.164	
2	676.126.000	600	1200	600	717.612	708.100	708.200	709.140	710.160	915.166	915.266	916.160	916.260	612.000
3	678.124.000	800	1200	400	717.812	708.100	708.200	709.160	710.140	915.184	915.284	916.140	916.240	612.000
4	678.126.000	800	1200	600	717.812	708.100	708.200	709.160	710.160	915.186	915.286	916.160	916.260	612.000
5	672.124.000	1200	1200	400	707.212	708.100	708.200	709.160	710.140	915.124	915.224	916.140	916.240	612.000
6	672.126.000	1200	1200	600	707.212	708.100	708.200	709.160	710.160	915.126	915.226	916.160	916.260	612.000
7	686.124.000	600	1200	400	717.612	708.100	708.200	709.160	710.140	915.164	915.264	916.140	916.240	612.000
8	686.126.000	600	1200	600	717.612	708.100	708.200	709.160	710.160	915.166	915.266	916.160	916.260	612.000
9	688.124.000	800	1200	400	717.812	708.100	708.200	709.170	710.140	915.184	915.284	916.140	916.240	612.000
10	688.126.000	800	1200	600	717.812	708.100	708.200	709.170	710.160	915.186	915.286	916.160	916.260	612.000
11	682.124.000	1200	1200	400	707.212	708.100	708.200	709.180	710.140	915.124	915.224	916.140	916.240	612.000
12	682.126.000	1200	1200	600	707.212	708.100	708.200	709.180	710.160	915.126	915.226	916.160	916.260	612.000

#### INFORMATION

\* For original dimensions please check the (2D drawing) soft copies.

\*\* 200mm plinth corner are using with 100mm height covers.Front and side plinth covers should order two pieces each.

## MONTAJ PLAKASI MONTAJ MOUNTING PLATE ASSEMBLY

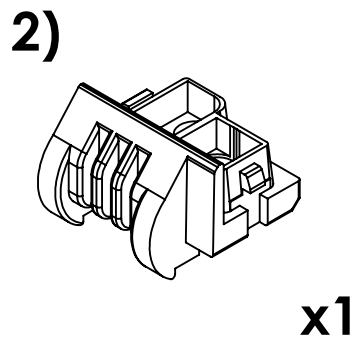
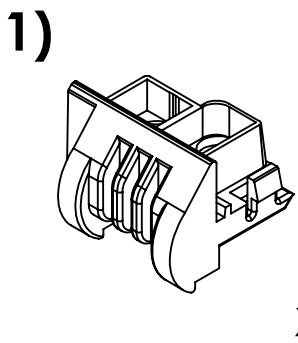
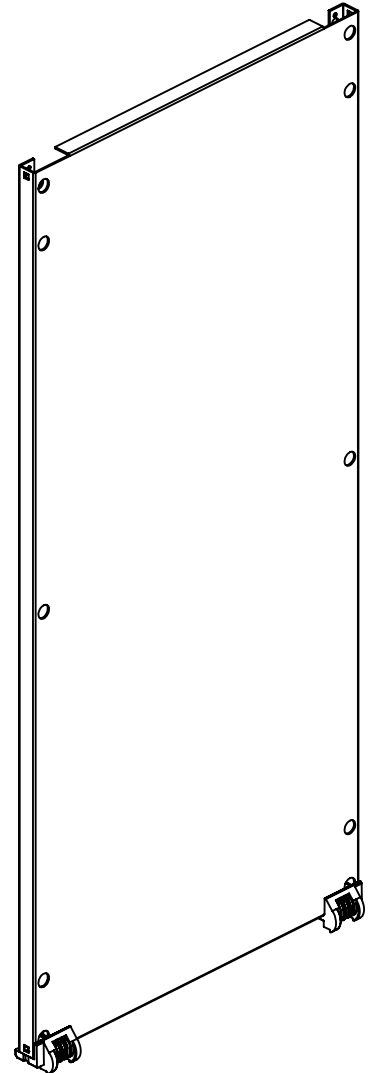
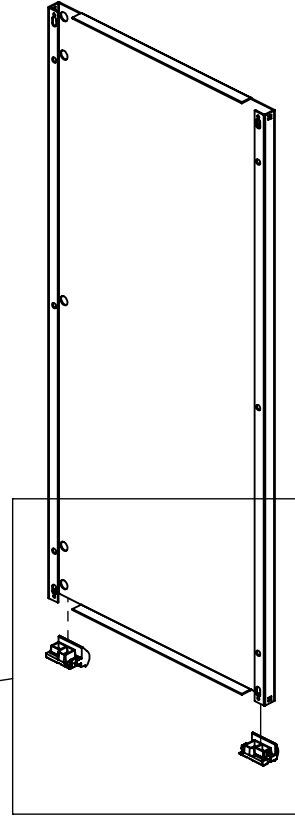
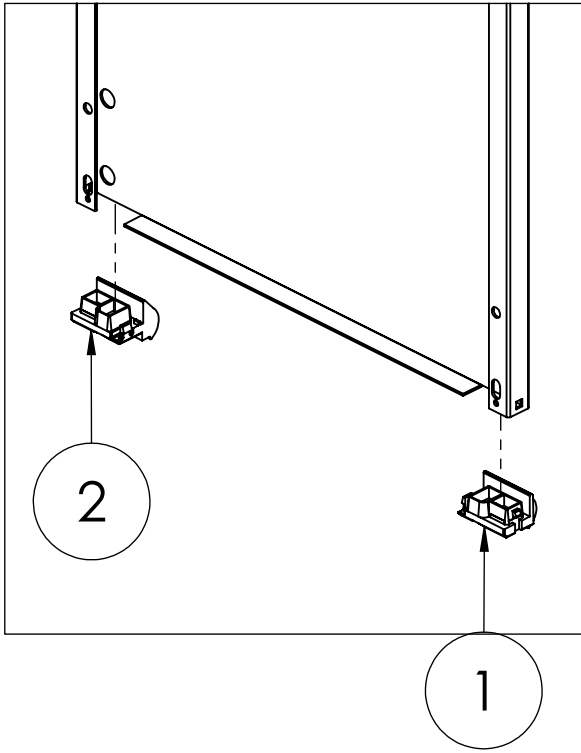
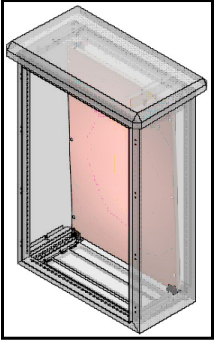



**MONTAJ PLAKASI ARKA SABİT POZİSYON**  
**MOUNTING PLATE REAR FIXED POSITION**

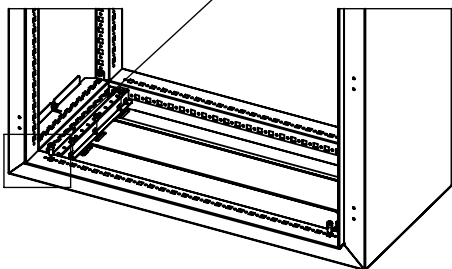
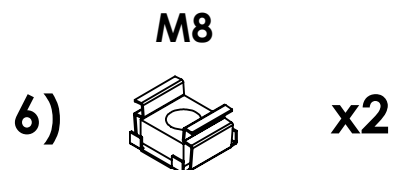
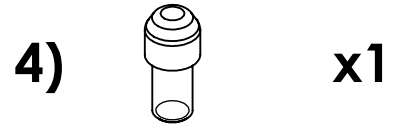
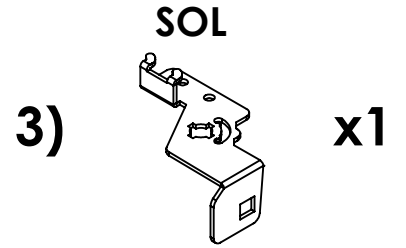
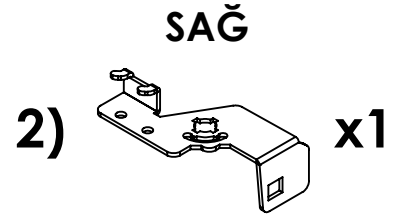
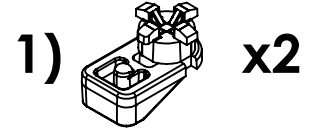
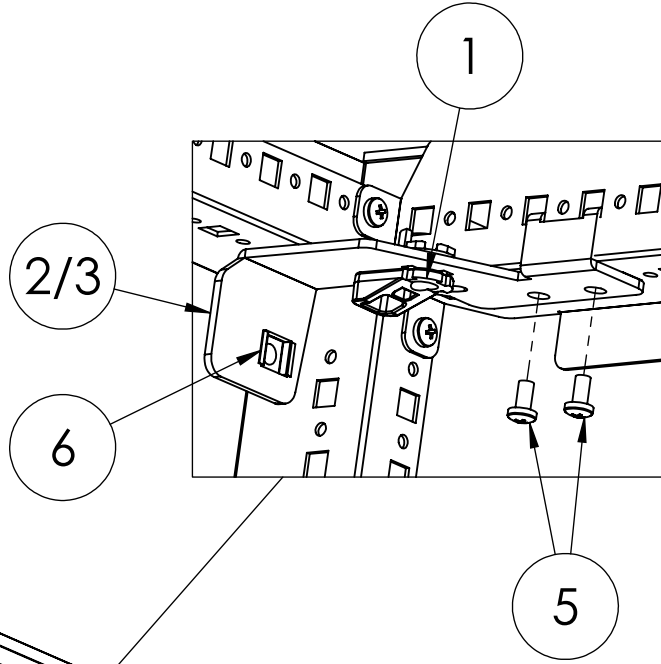
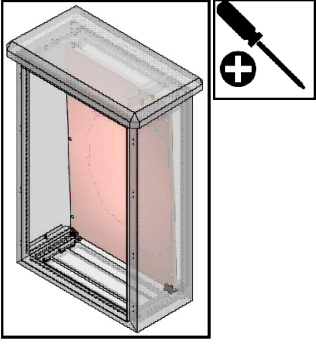

## MONTAJ PLAKASI ARKA SABİT POZİSYON MOUNTING PLATE REAR FIXED POSITION

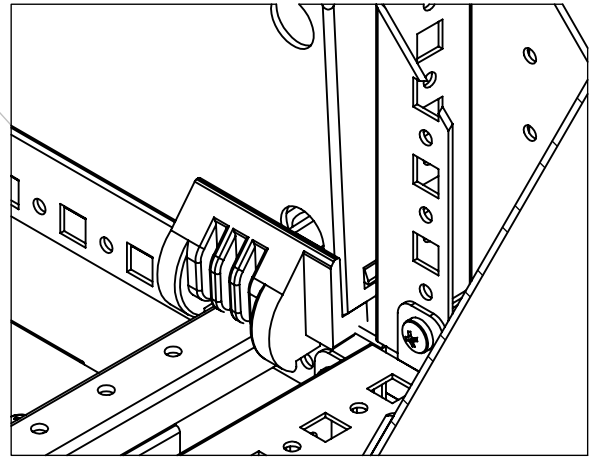
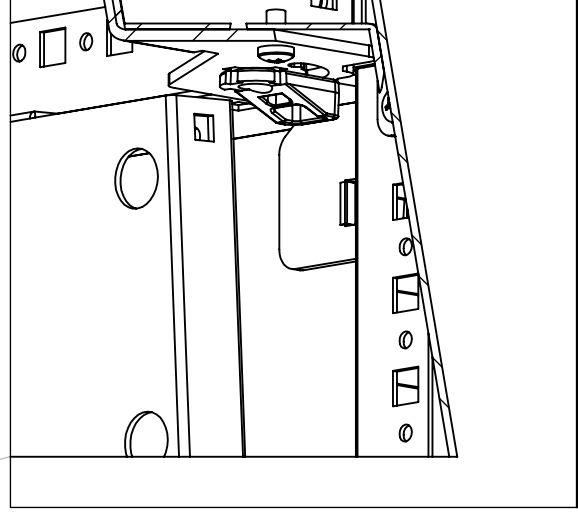
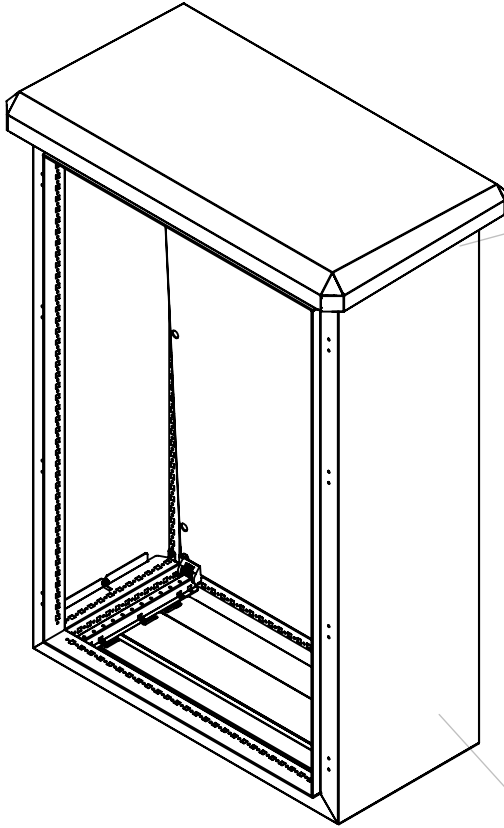
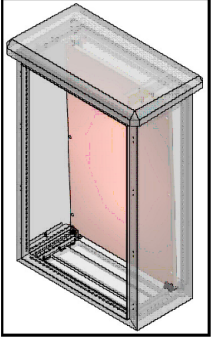

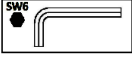
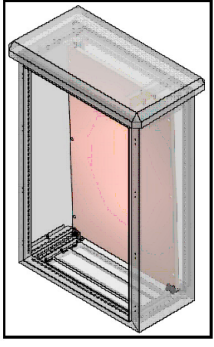

## MONTAJ PLAKASI ARKA SABİT POZİSYON MOUNTING PLATE REAR FIXED POSITION

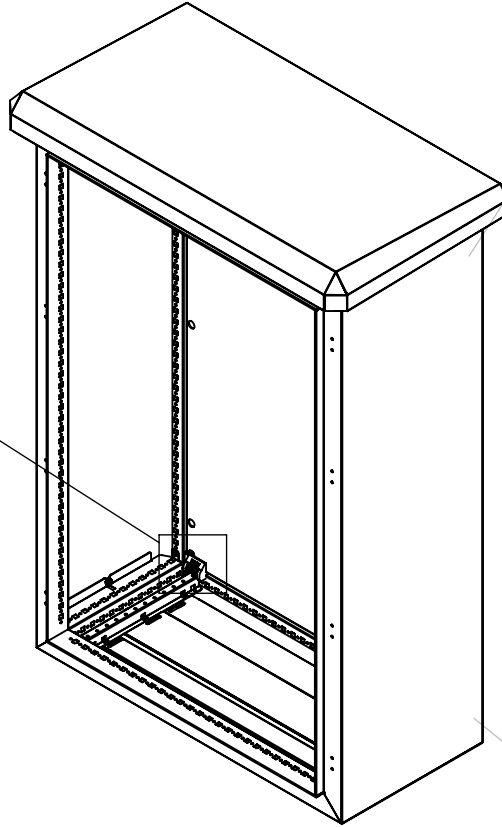
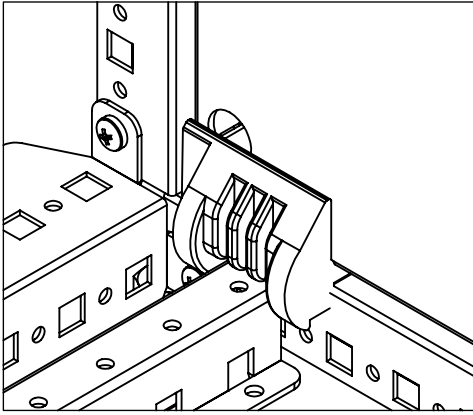
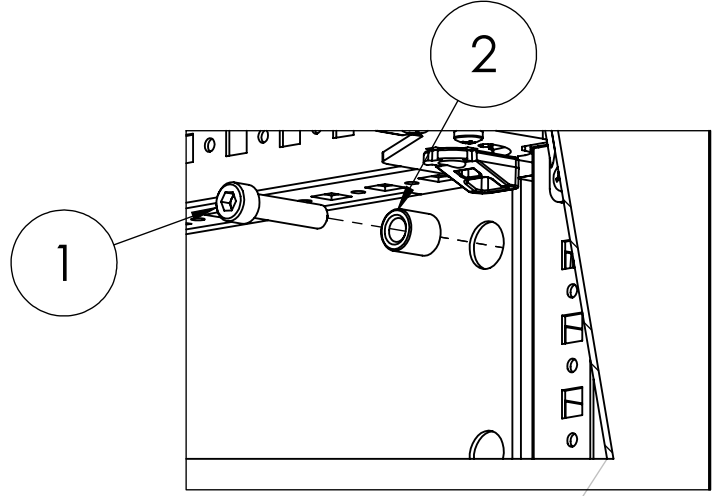

1) **M8x35** x2

2) **M8** x2

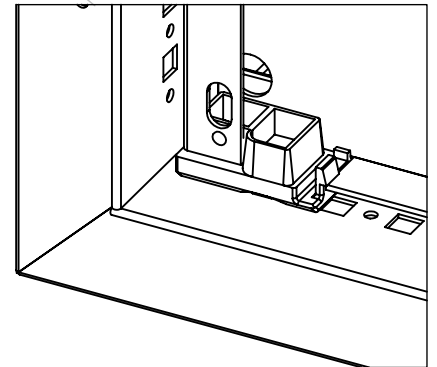

**MONTAJ PLAKASI HAREKETLİ POZİSYON**  
**MOUNTING PLATE MOVEABLE POSITION**

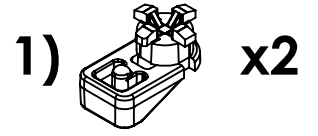
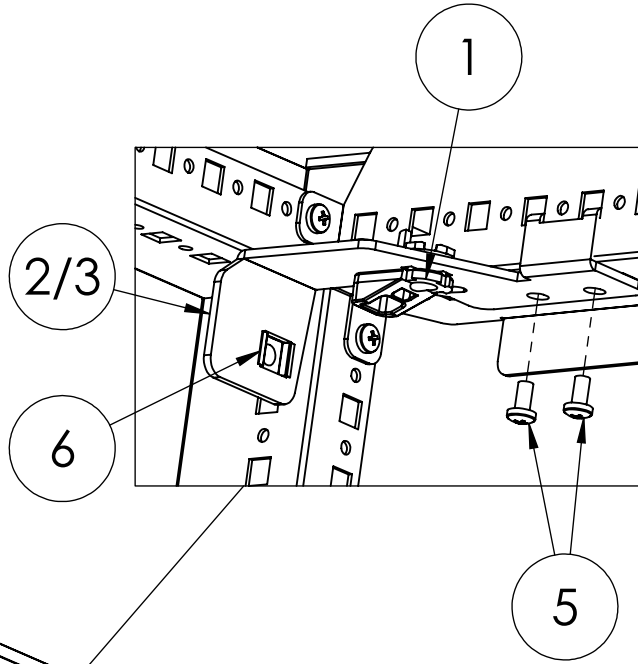
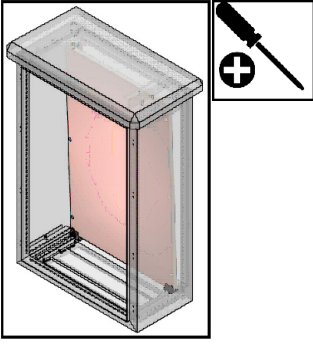

SAĞ

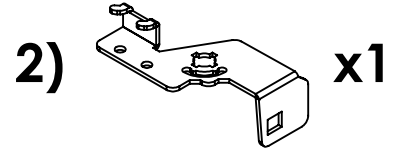

SOL

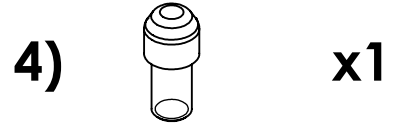
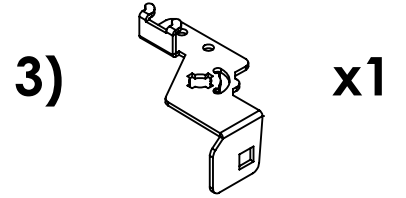

M5x10

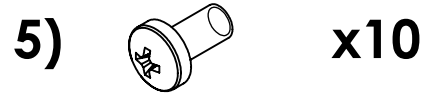

M8

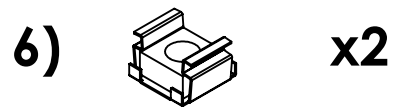

SAĞ

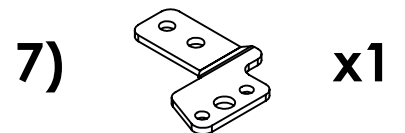

SOL

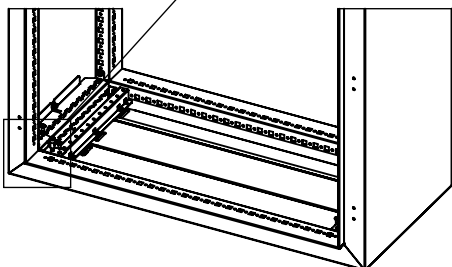
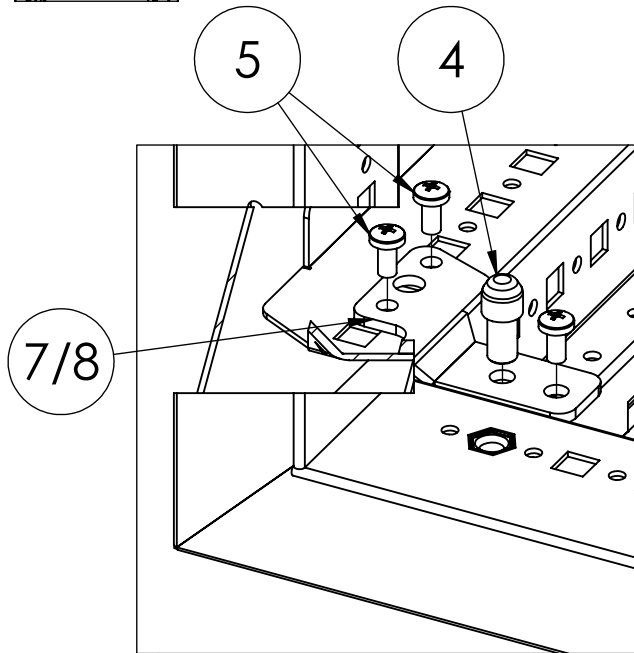
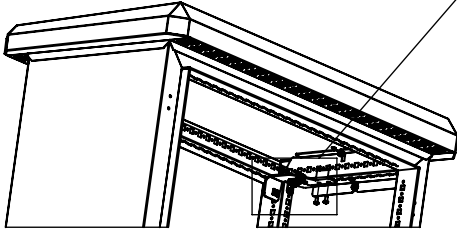

## MONTAJ PLAKASI HAREKETLİ POZİSYON MOUNTING PLATE MOVEABLE POSITION

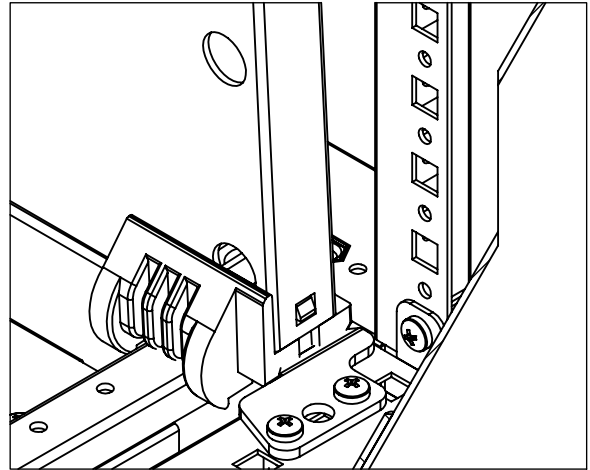
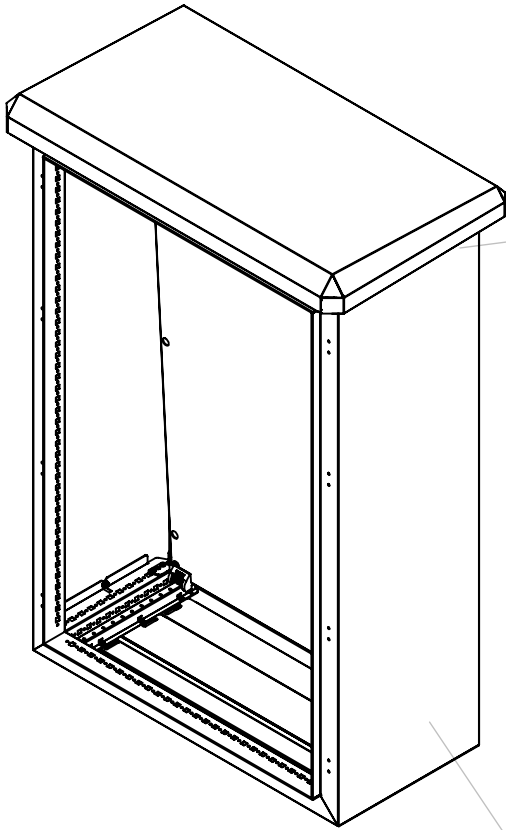
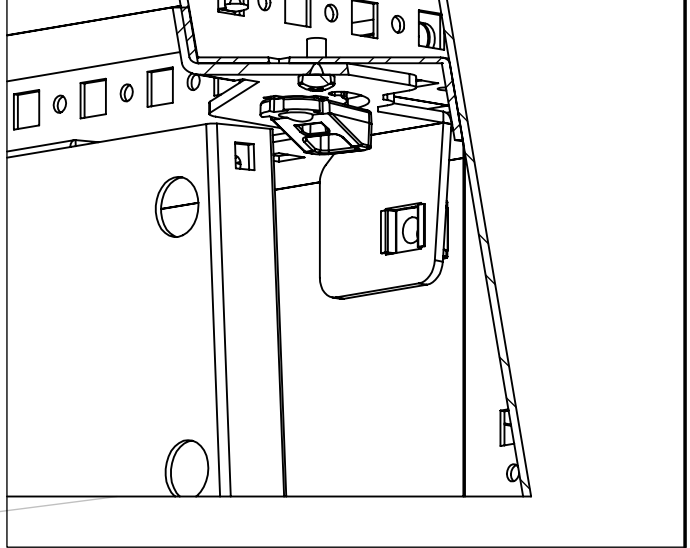
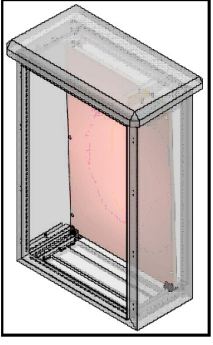

**MONTAJ PLAKASI HAREKETLİ POZİSYON**  
**MOUNTING PLATE MOVEABLE POSITION**

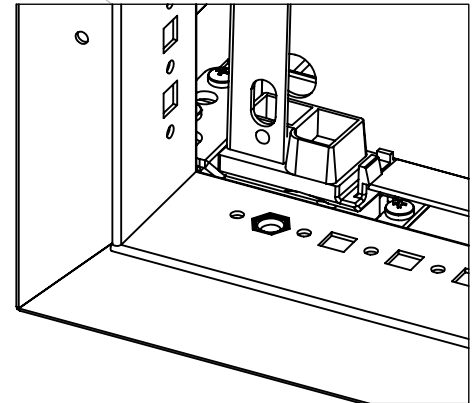
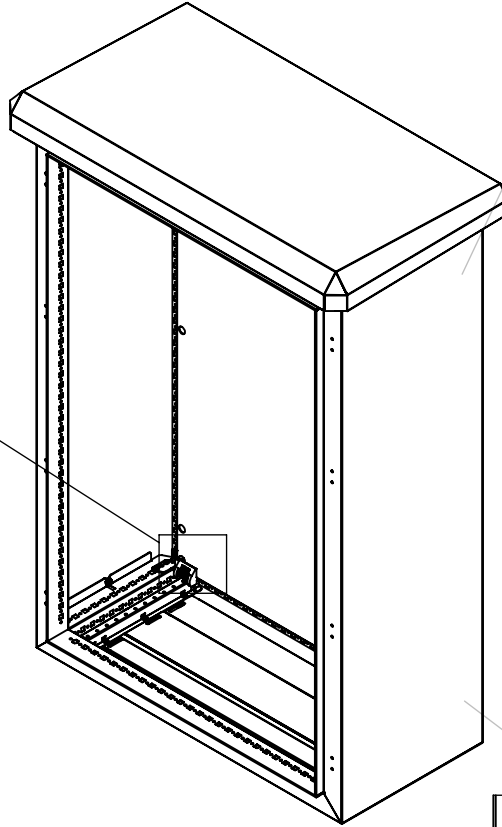
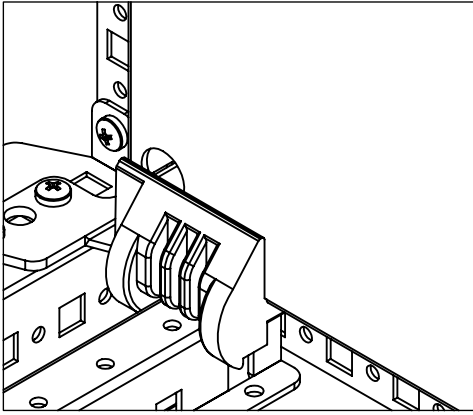
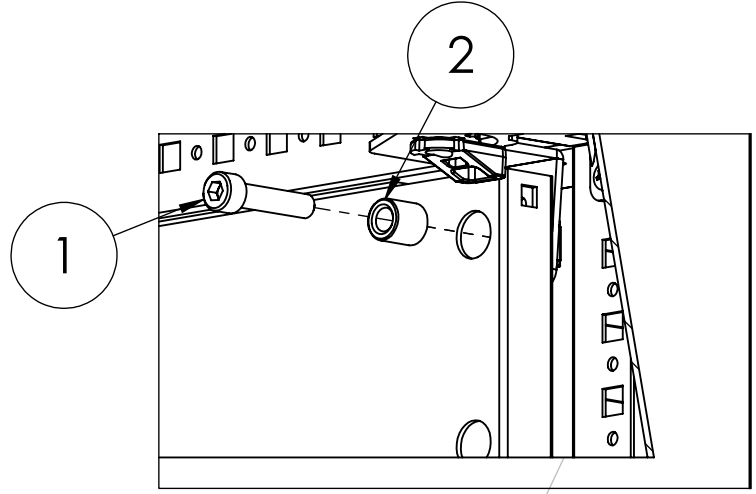
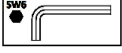
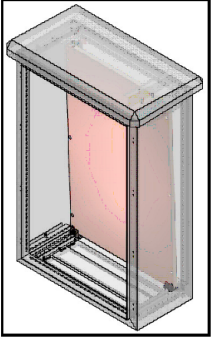

**M8x35**  
1)  **x2**

**M8**  
2)  **x2**

**KALDIRMA KANCASI MONTAJ**  
**EYEBOLT ASSEMBLY**

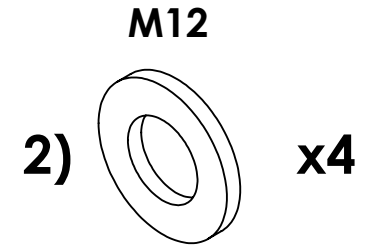
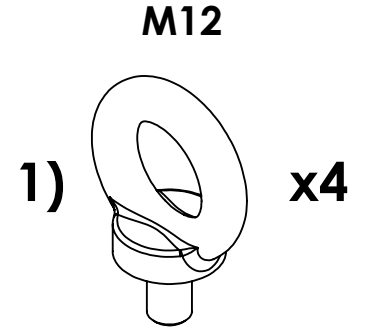
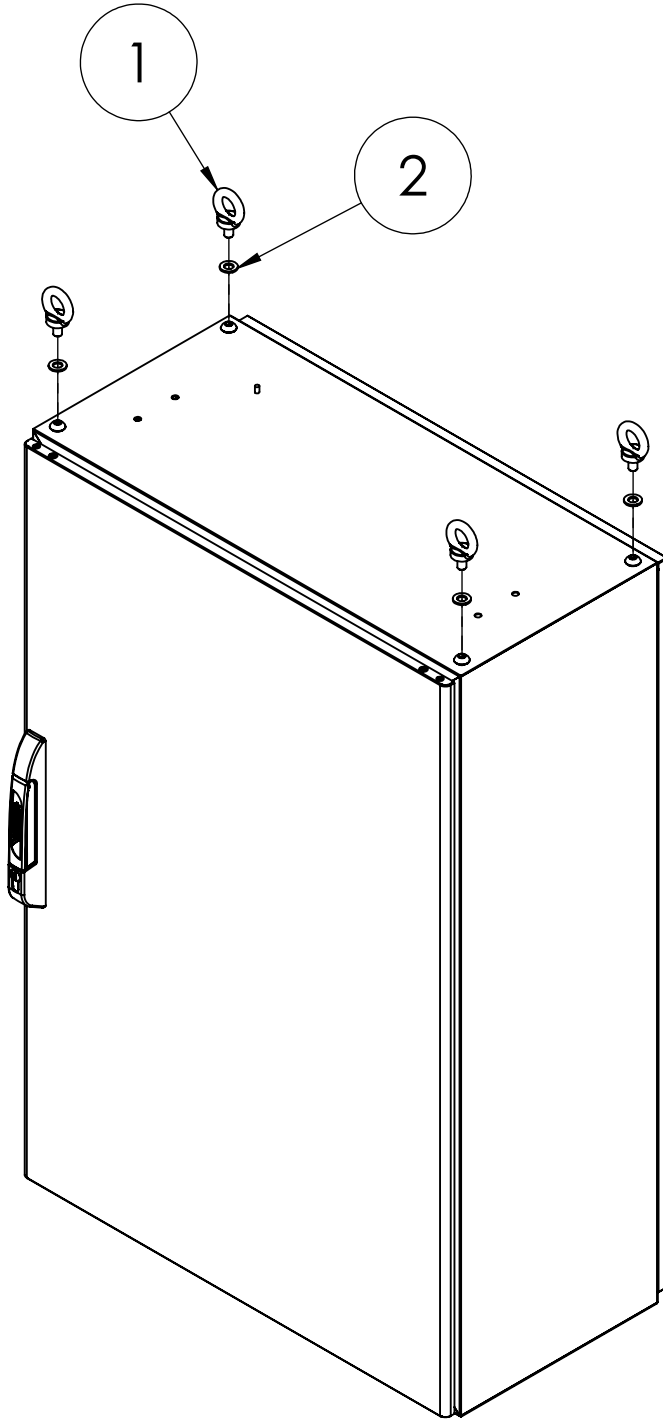

## TEK KAPI YÖN DEĞİŞTİRME CHANGING SINGLE DOOR OPENING DIRECTION

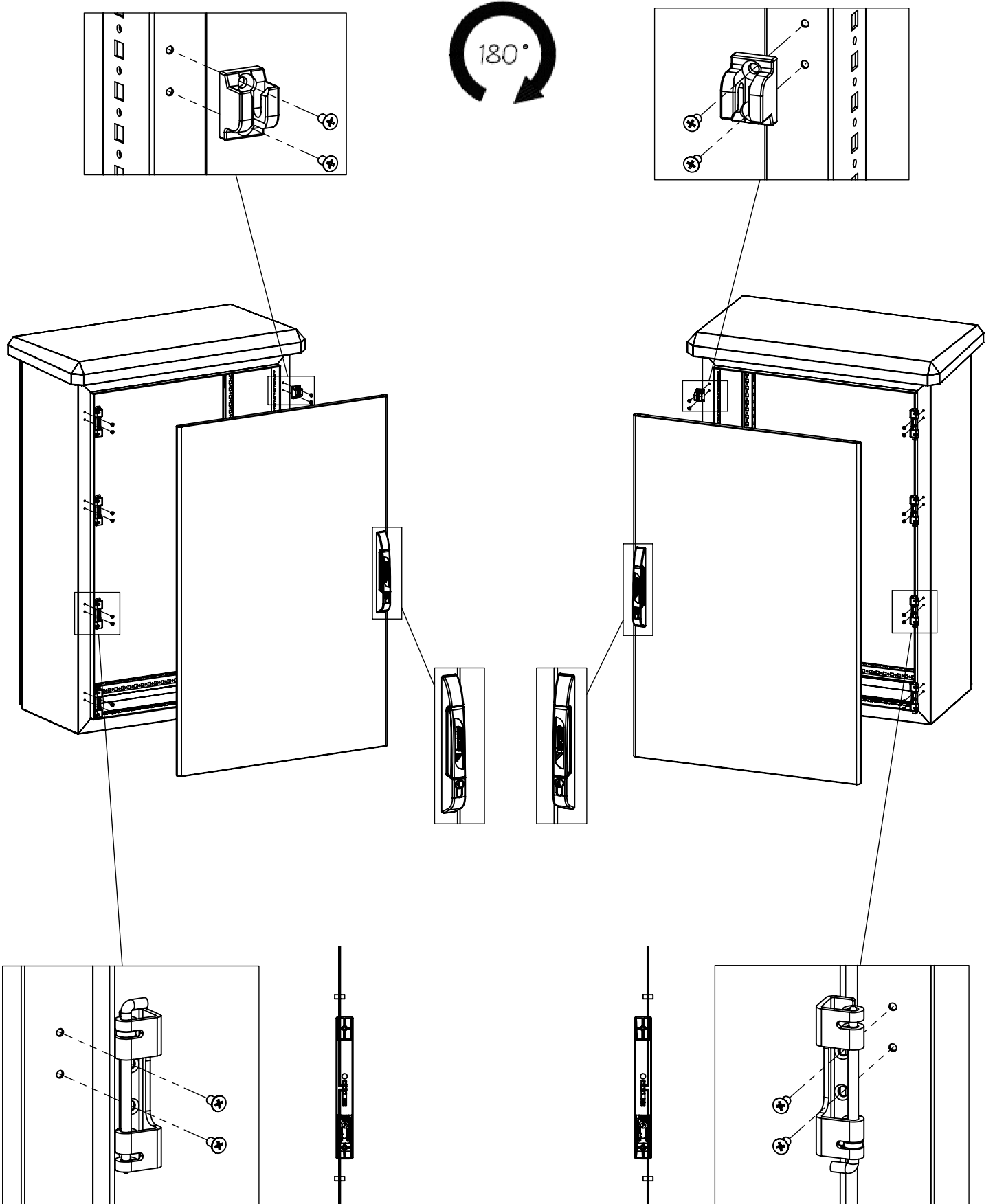



## ÇİFT KAPI YÖN DEĞİŞTİRME CHANGING DOUBLE DOOR OPENING DIRECTION

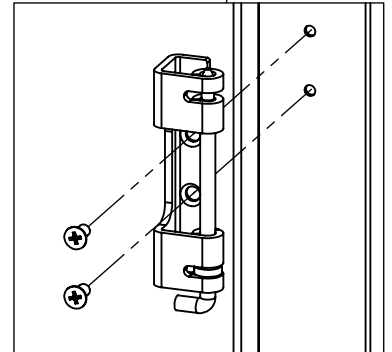
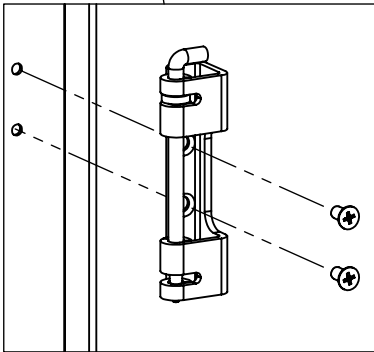
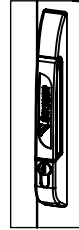
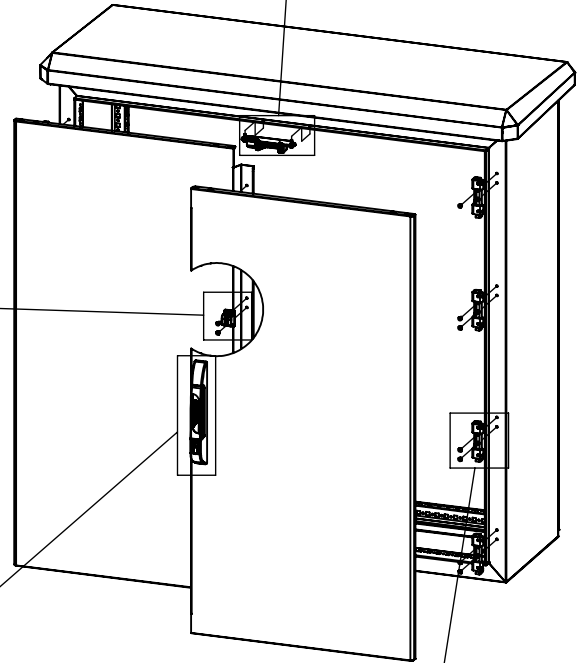
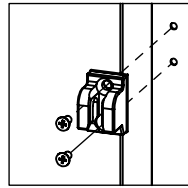
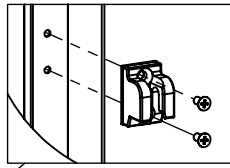
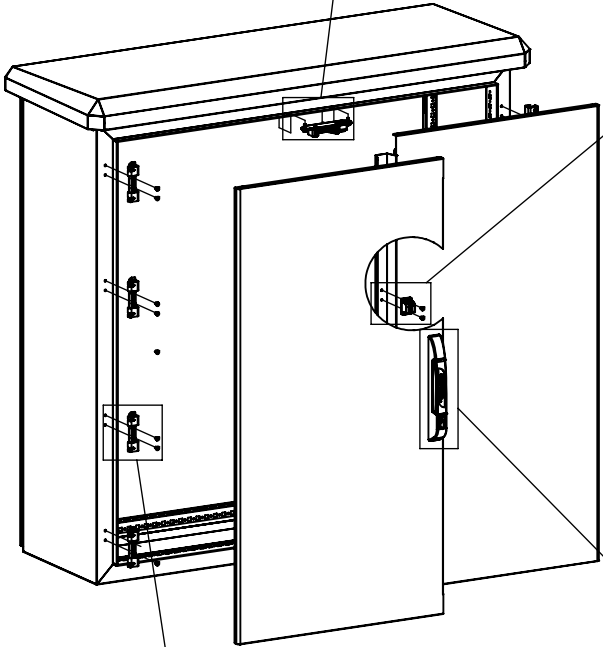
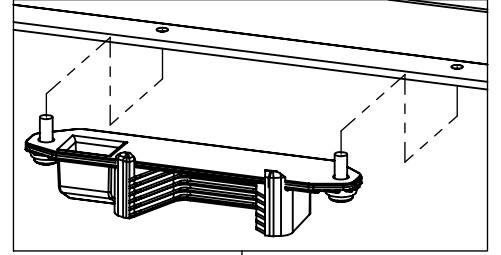
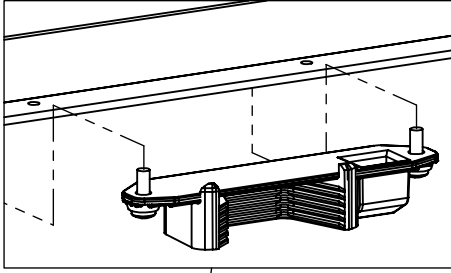

KİLİT ARKA GÖRÜNÜM  
BACK SIDE VIEW OF THE LOCK

KİLİT ARKA GÖRÜNÜM  
BACK SIDE VIEW OF THE LOCK

## BAZA KÖŞESİ MONTAJ PLINTH CORNER PARTS ASSEMBLY

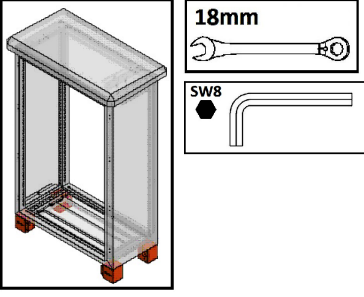

M12x30

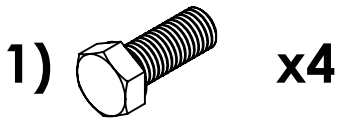

M12

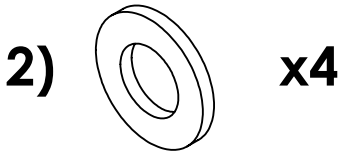

M12

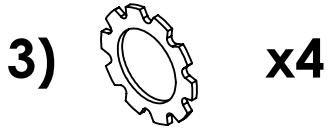

M8x16

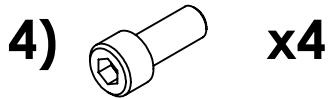

M8

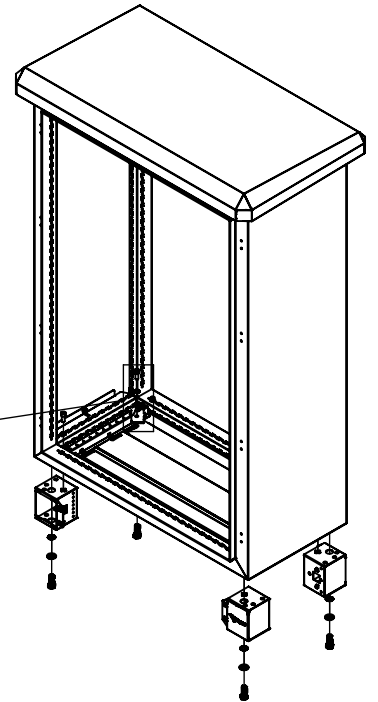
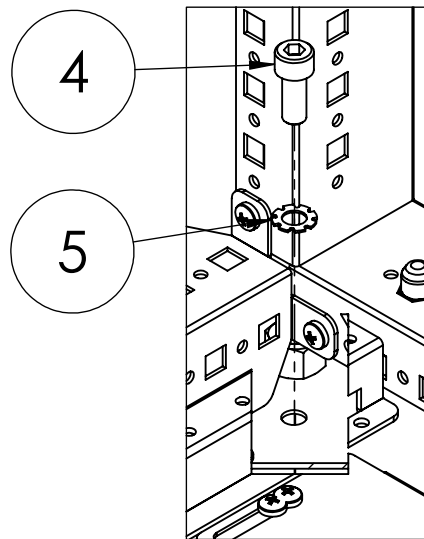
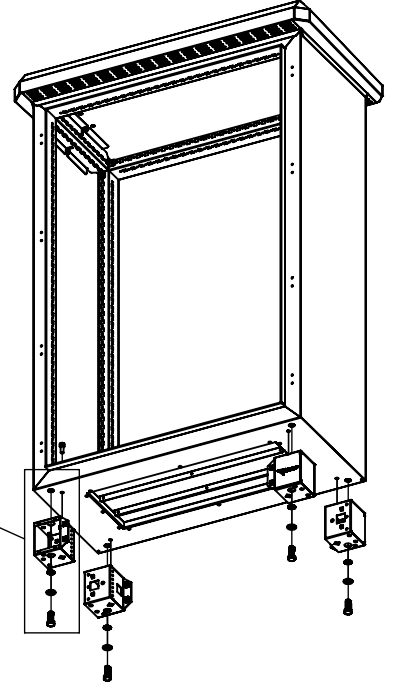
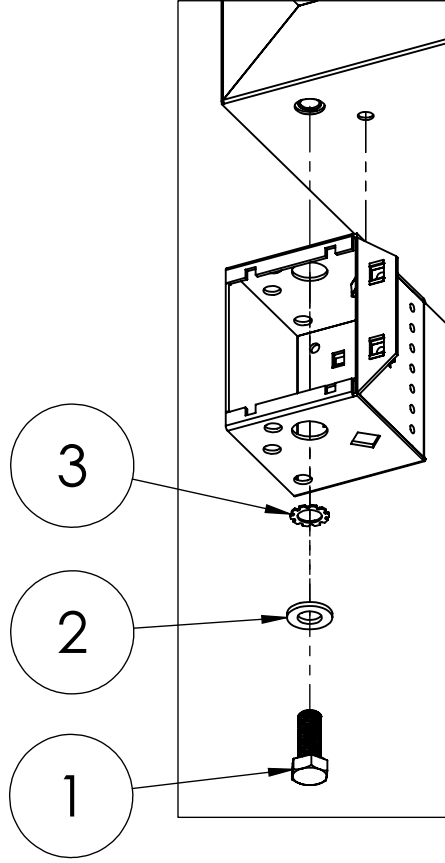
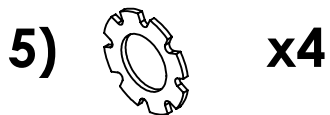

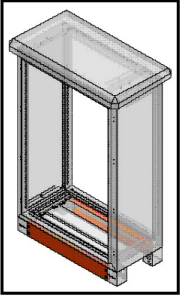

## BAZA KÖŞESİ ÖN & ARKA KAPAK MONTAJ PLINTH FRONT & BACK COVER PARTS ASSEMBLY

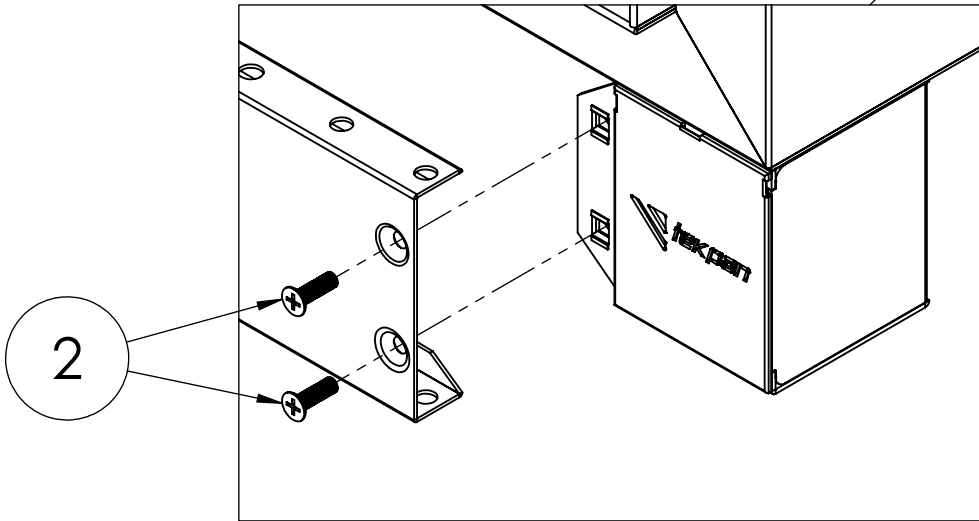
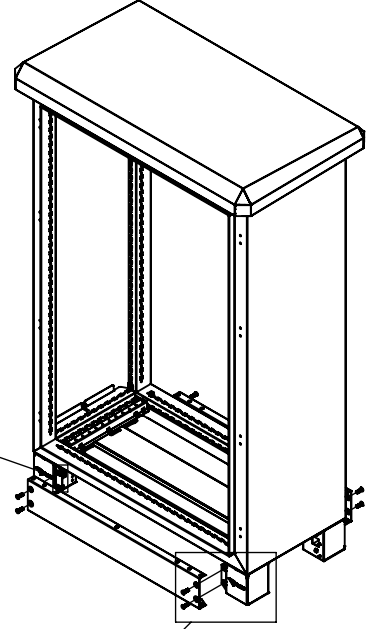
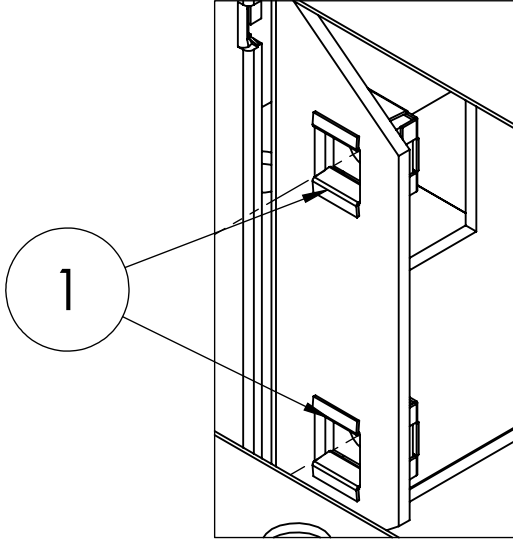

M6

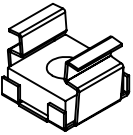
1)  x8

M6x20

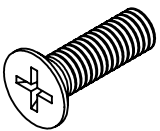
2)  x8

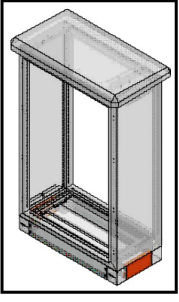

## BAZA KÖŞESİ YAN KAPAK MONTAJ PLINTH SIDE COVER PARTS ASSEMBLY

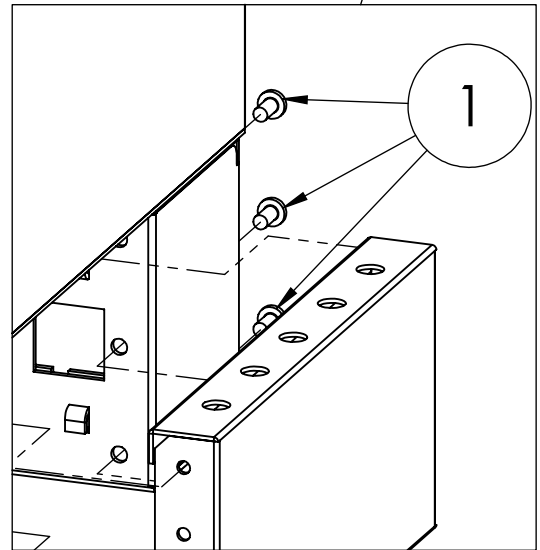
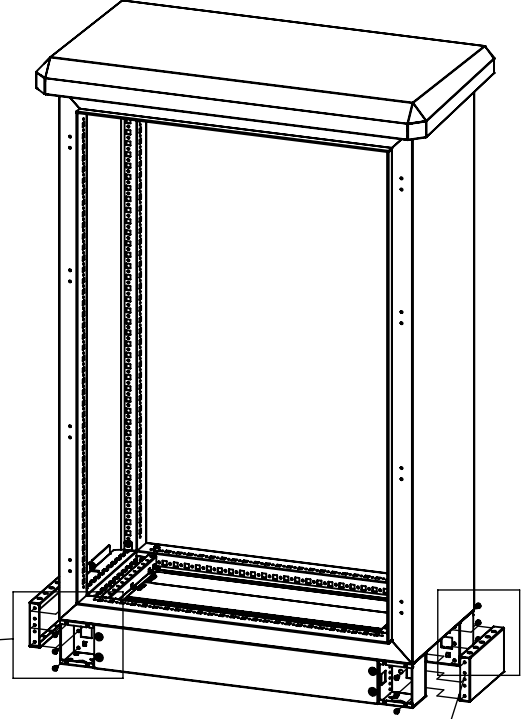
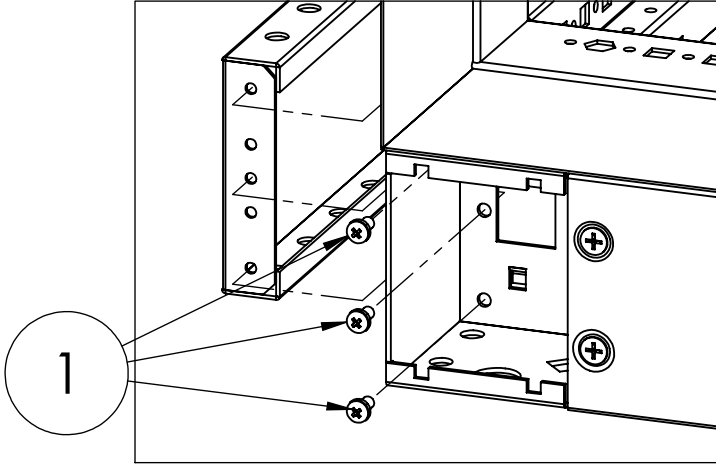

M5x10

1)

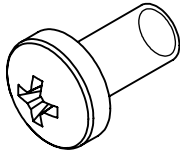

x12

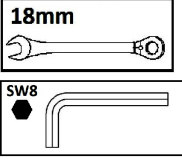
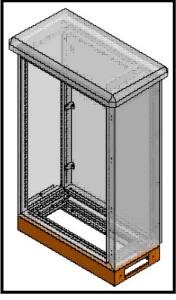

## BLOK BAZA MONTAJ BLOCK PLINTH ASSEMBLY

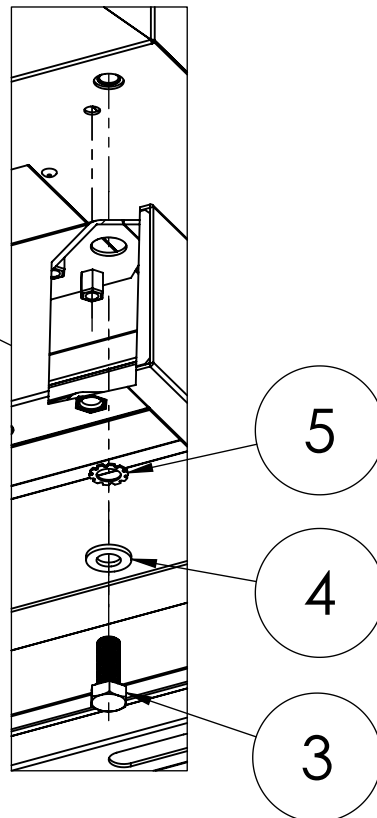
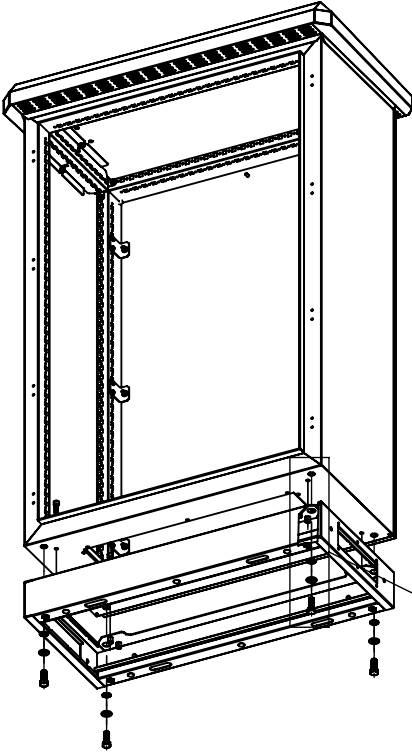
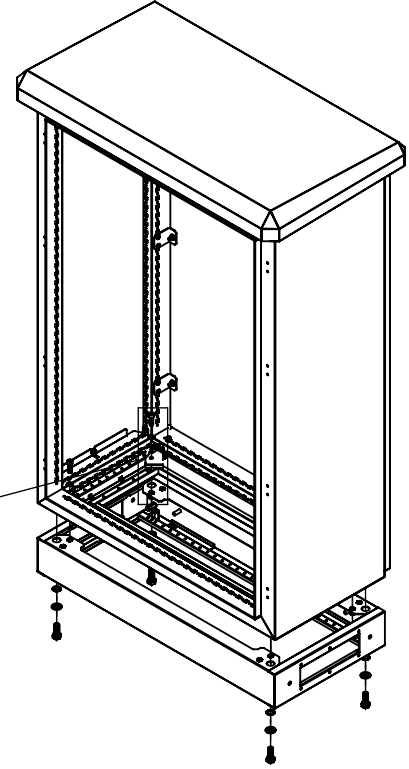
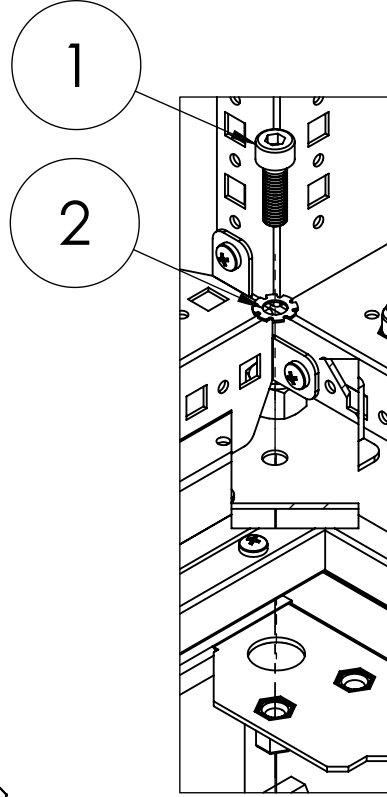

M8x25

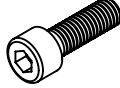
1)  x4

M8

2)  x4

M12x30

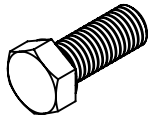
3)  x4

M12

4)  x4

M12

5)  x4

**BLOK BAZA YAN KAPAK MONTAJ**  
**BLOCK PLINTH SIDE COVER ASSEMBLY**

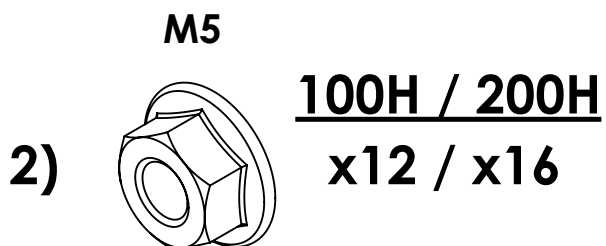
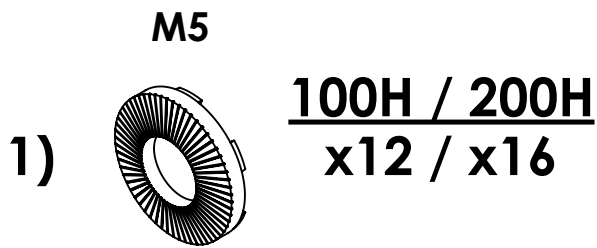
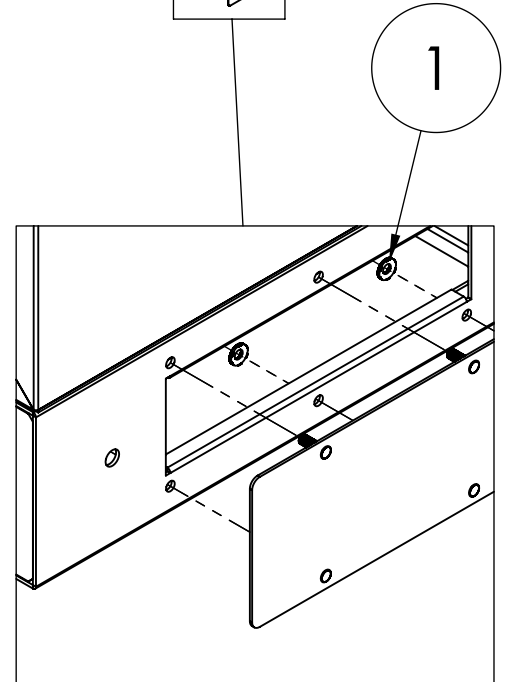
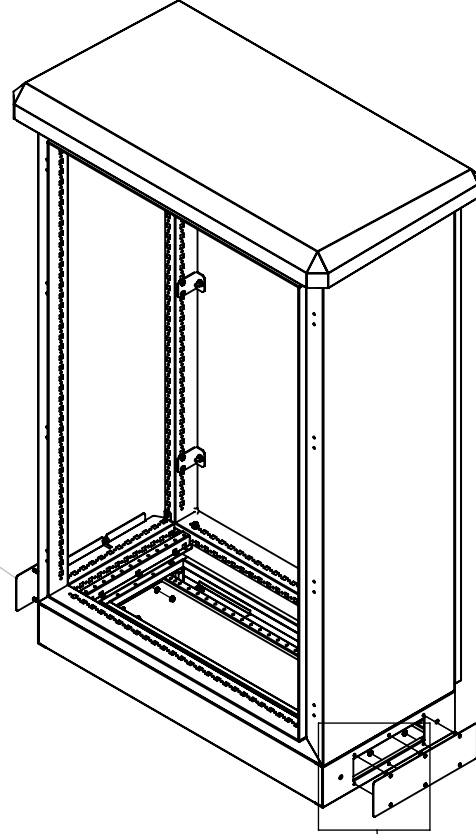
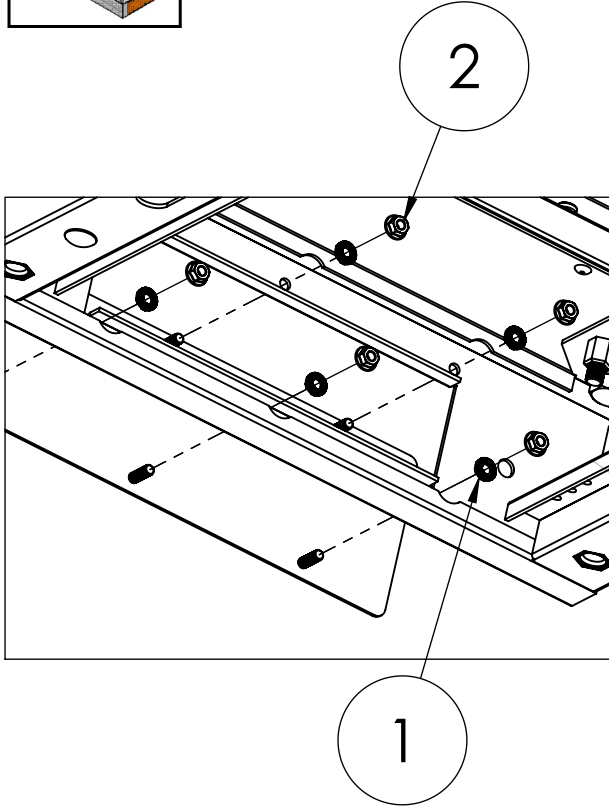
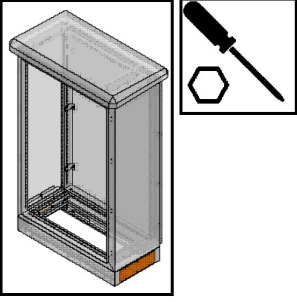

**TAŞIMA BİLGİLERİ**  
**TRANSPORT INFORMATION**

**1000 kg**

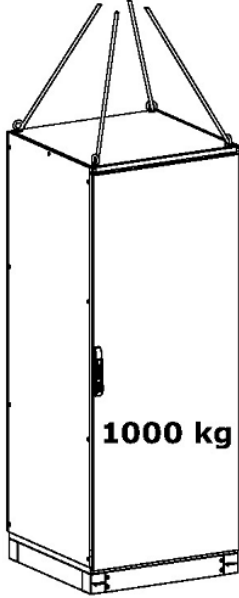

**2000 kg**

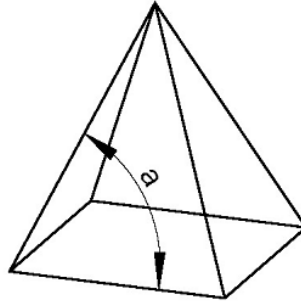
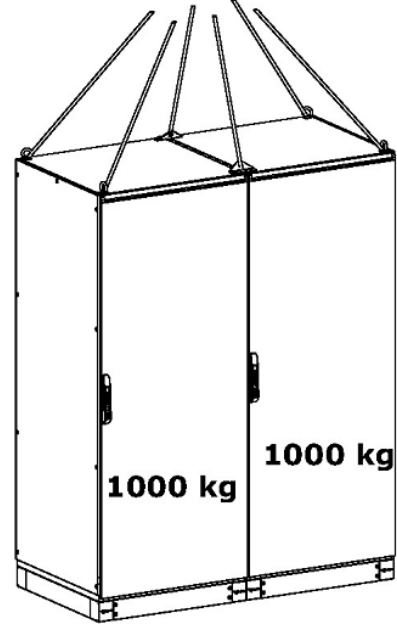

IDEAL  $\alpha \geq 90^\circ$   
MIN  $\alpha \geq 75^\circ$

**1000 kg**

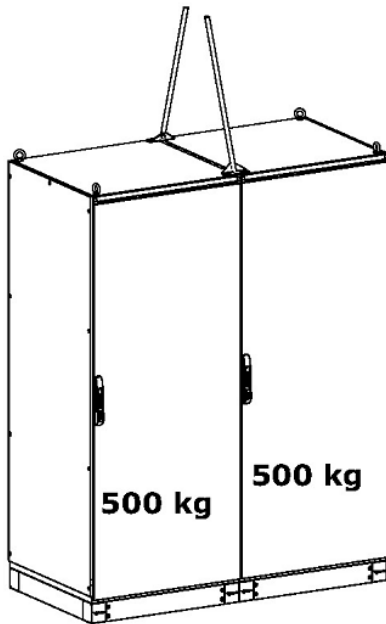

**2000 kg**

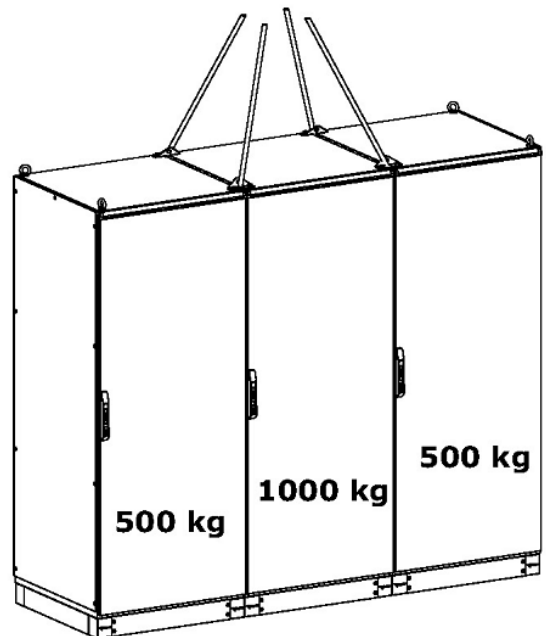

## TAŞIMA BİLGİLERİ TRANSPORT INFORMATION

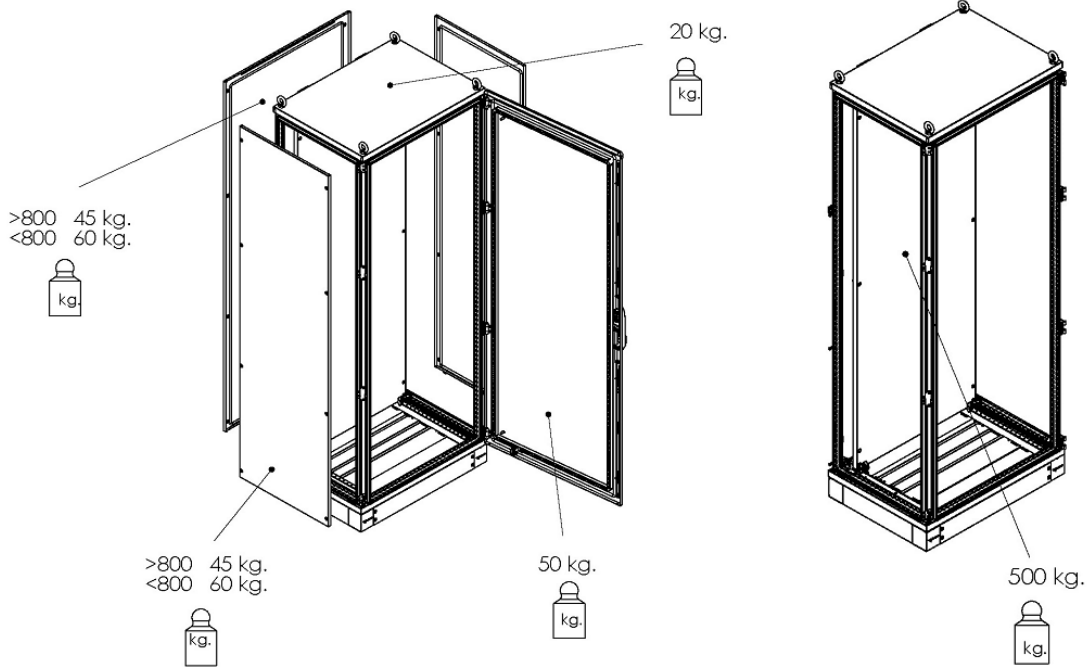
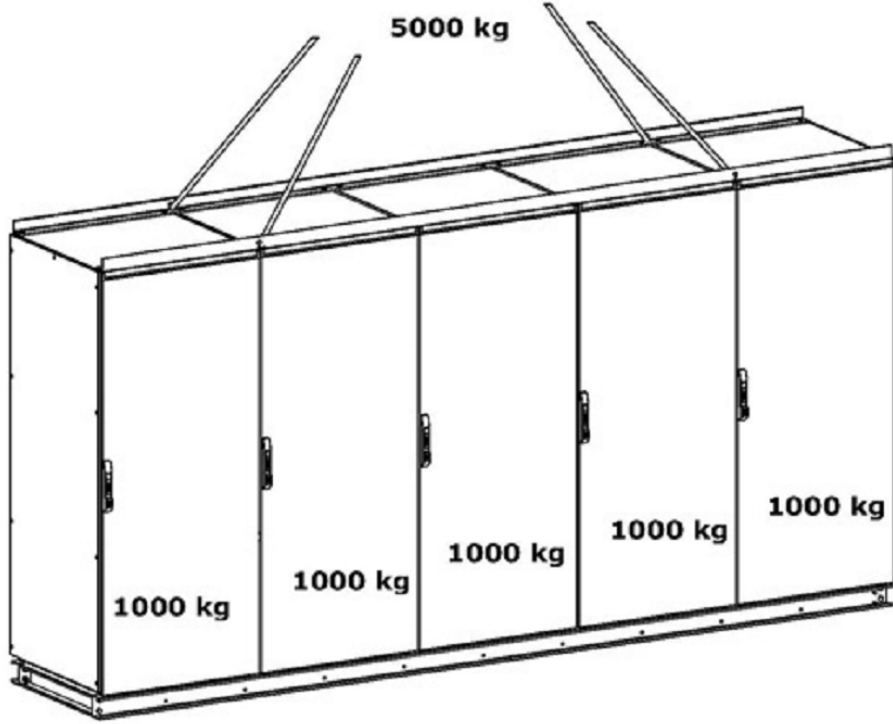

\* Kesilebilir atkı sistemi kullanılarak 500 kg. ek yük montaj edilebilir.

\* By using plug-in rail brackets and scissile rails inside the enclosure extra 500 kg. can be loaded.



## HC YAĞMURLUK MONTAJ RAIN CANOPY ASSEMBLY

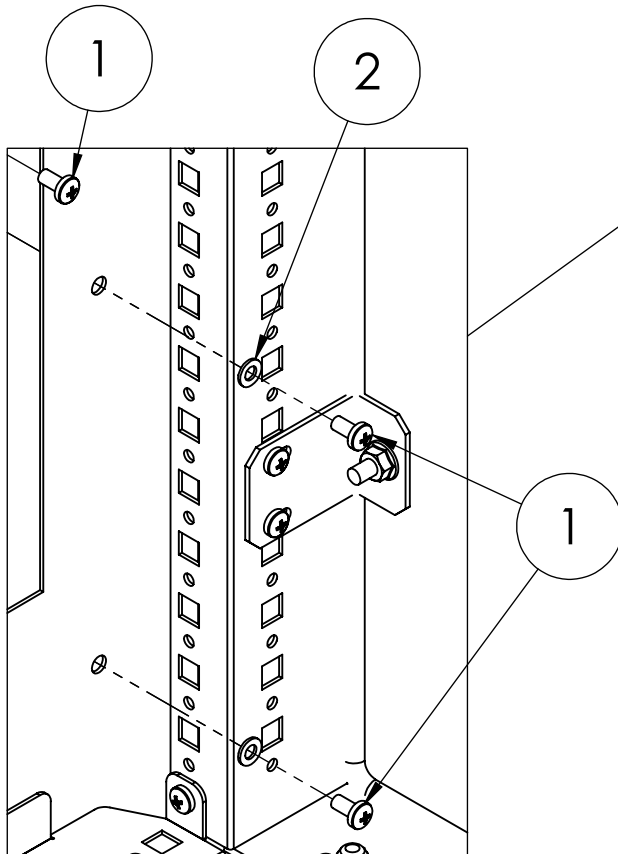
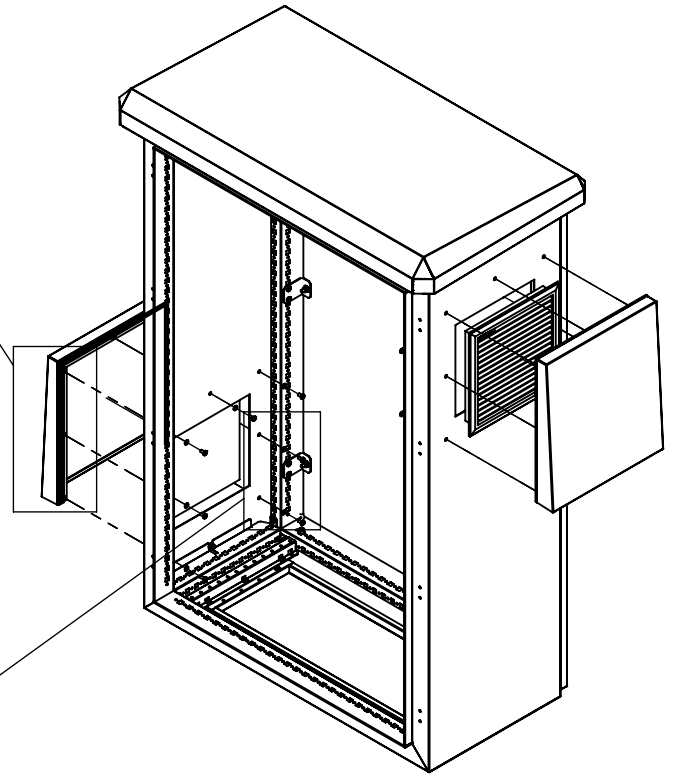
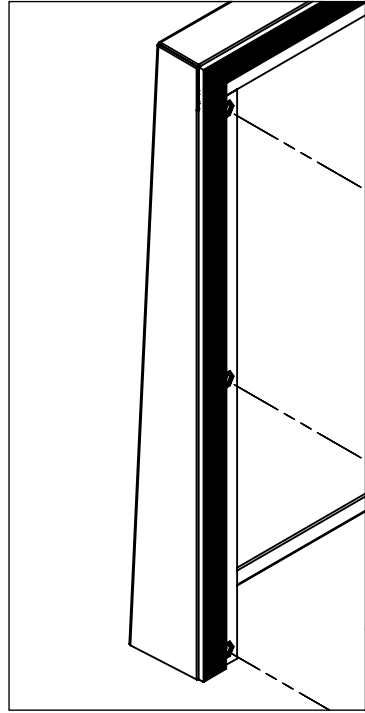
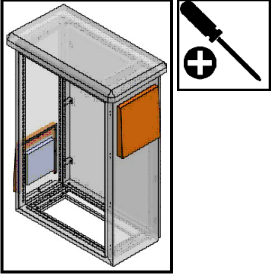



**1 ADET YAĞMURLUK İÇİN  
FOR 1 PCS. RAIN CANOPY**

1)  x7

2)  x7

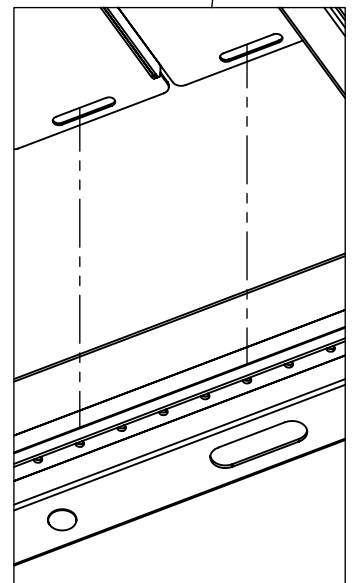
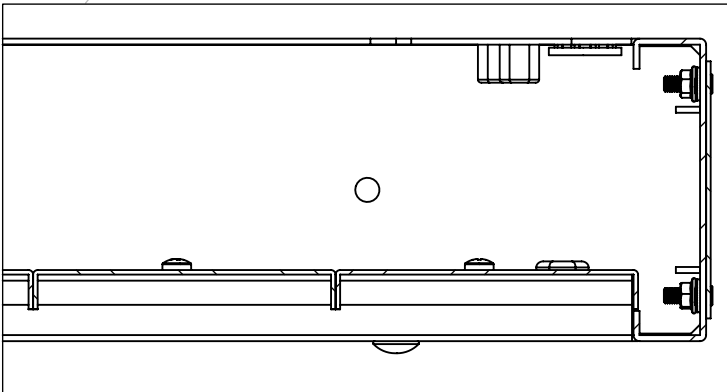
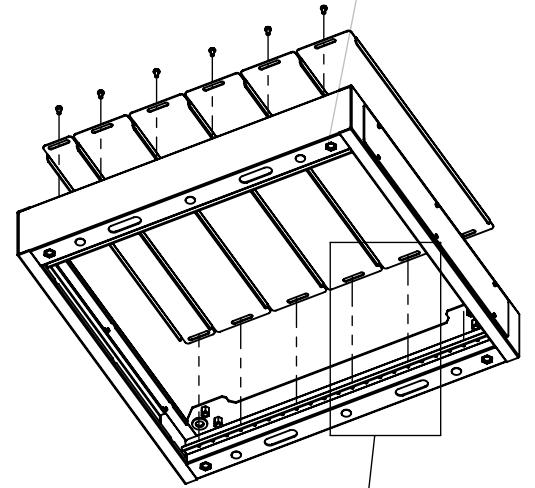
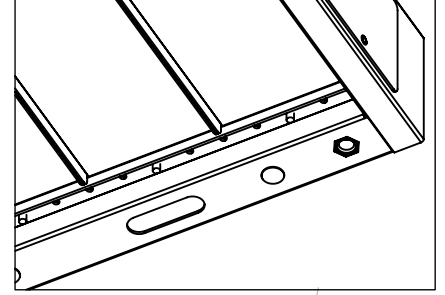
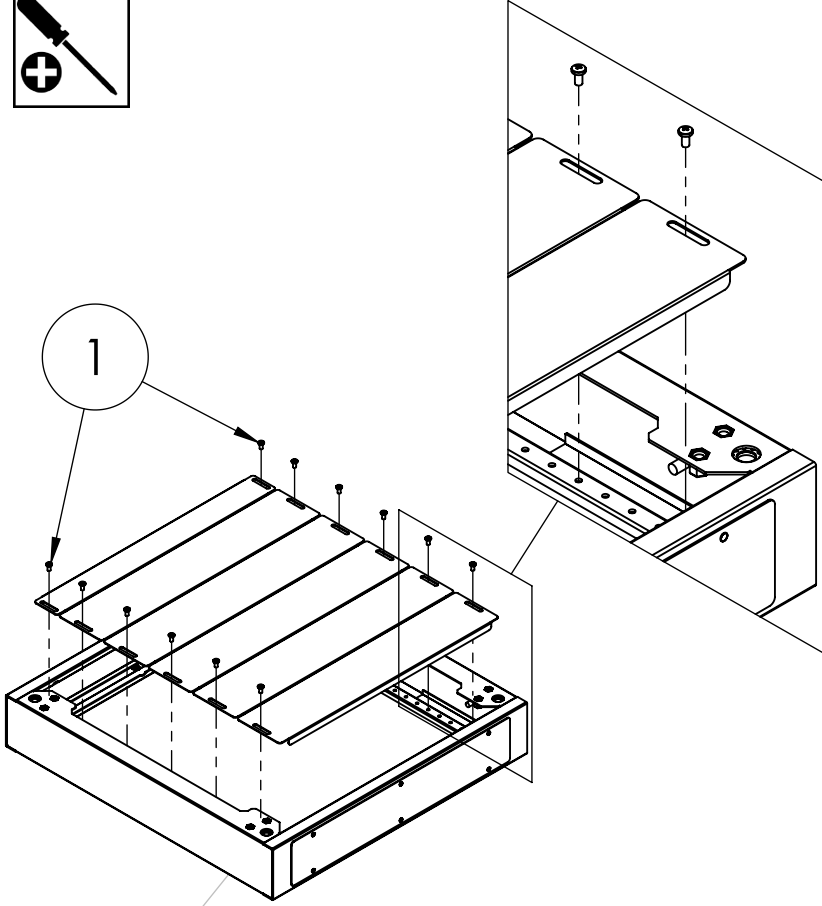
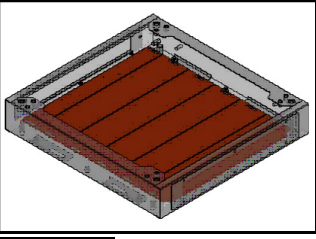
**BLOK BAZA TABAN KAPAMA MONTAJ**  
**BLOCK PLINTH BASE COVER ASSEMBLY**



1)  x2