

SWING FRAME ASSEMBLY INTRODUCTION

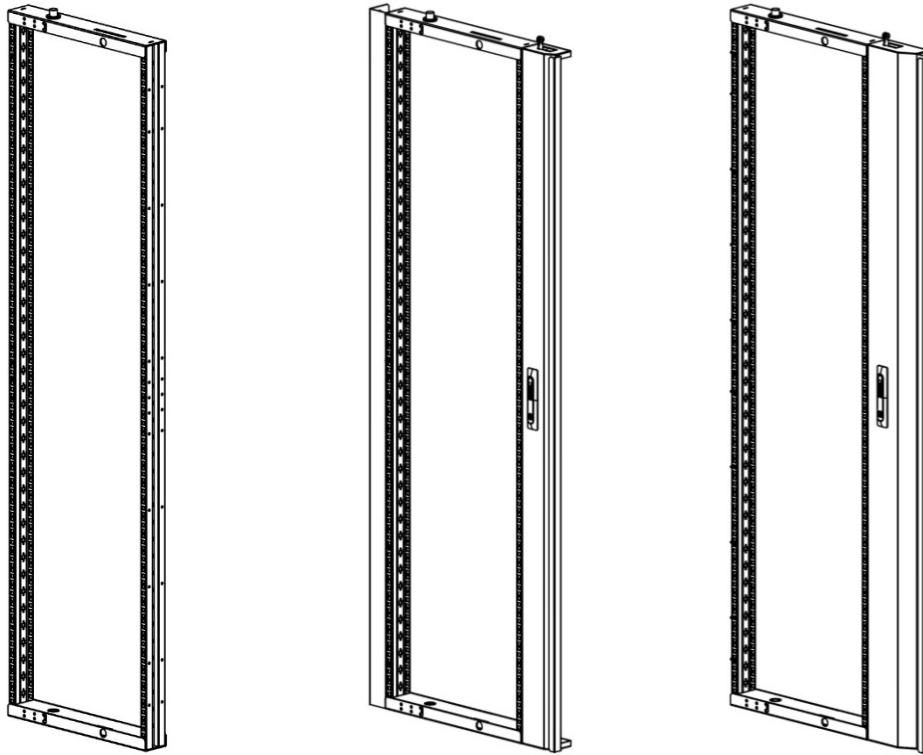

Height Units	22U			31U			35U			40U			44U		
Model	600W	800W Side	800W Center	600W	800W Side	800W Center	600W	800W Side	800W Center	600W	800W Side	800W Center	600W	800W Side	800W Center
Product No.	944.120	944.121	944.122	944.160	944.161	944.162	944.180	944.181	944.182	944.200	944.201	944.202	944.220	944.221	944.222
Enclosure Height(mm)	1200	1200	1200	1600	1600	1600	1800	1800	1800	2000	2000	2000	2200	2200	2200
Swing Frame Height (mm)	1055,5	1055,5	1055,5	1455,5	1455,5	1455,5	1655,5	1655,5	1655,5	1855,5	1855,5	1855,5	2055,5	2055,5	2055,5
Swing Frame Depth (mm)	75	75	75	75	75	75	75	75	75	75	75	75	75	75	75

**SWING FRAME
ASSEMBLY GUIDE**



■ Contents

Tools&Equipment Informations

Screw/Bolt/Special Parts for Assembly& Tool Symbol Guide1

SWING FRAME ASSEMBLY

Swing Frame 600W.....2

Swing Frame 800W CENTER Assembly Model.....3

Swing Frame 800W SIDE Assembly Model.....4

Information Opens From Right And Left.....5

Opens From Right to Left.....6

Opens From Left to Right.....7

INSTALLATION DEPTH.....8

Swing Frame Rails Assembly For Teos9

Swing Frame Rails Assembly For Neo.....10

Swing Frame Rails Assembly For 1200W.....11

Swing Frame Assembly (130 ANGLE).....12-13

Swing Frame Stopper Assembly.....14-15

ACCESSORIES.....16

180 Angle Hinge Kit Assembly For Center Model.....17

180 Angle Hinge Kit Assembly For Side Model18

Swing Frame Assembly (180 Angle).....19

Door Holder Part Assembly For Short Type.....20

Door Holder Part Assembly For Long Type21

1200W Door Holder Part Assembly For Short Type.....22-23

EARTHING.....24

■ Torque Table for Screw/Bolt

■ Screw/Bolt/Special Parts for Assembly

■ Tools Symbol Guide

For 130 Angle

Hexagon Socket
Head Bolt



Plastic Cage
Nut

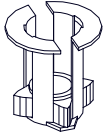

Flat Washer

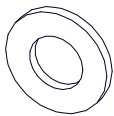

Toothed Lock
Washer

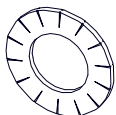

For 180 Angle

Pan Head
Screw

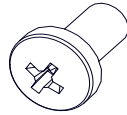

Hexagon Socket
Head Bolt

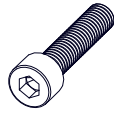

Plastic Cage
Nut



Flat Washer

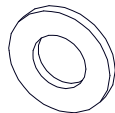

Toothed Lock
Washer

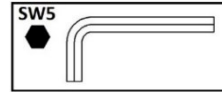
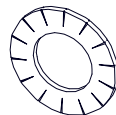

M6 Allen Key

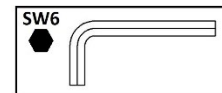

M8 Allen Key



Cross

■ Swing Frame 600W Assembly

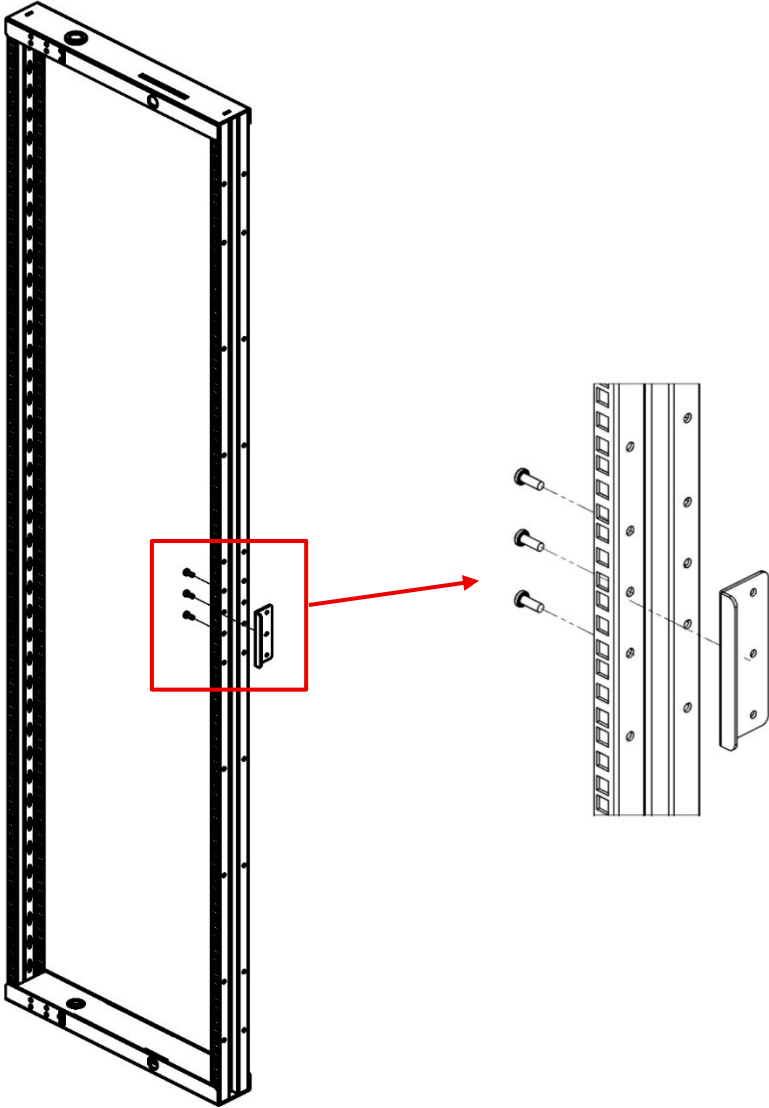

■ Swing Frame 800W CENTER Assembly Model

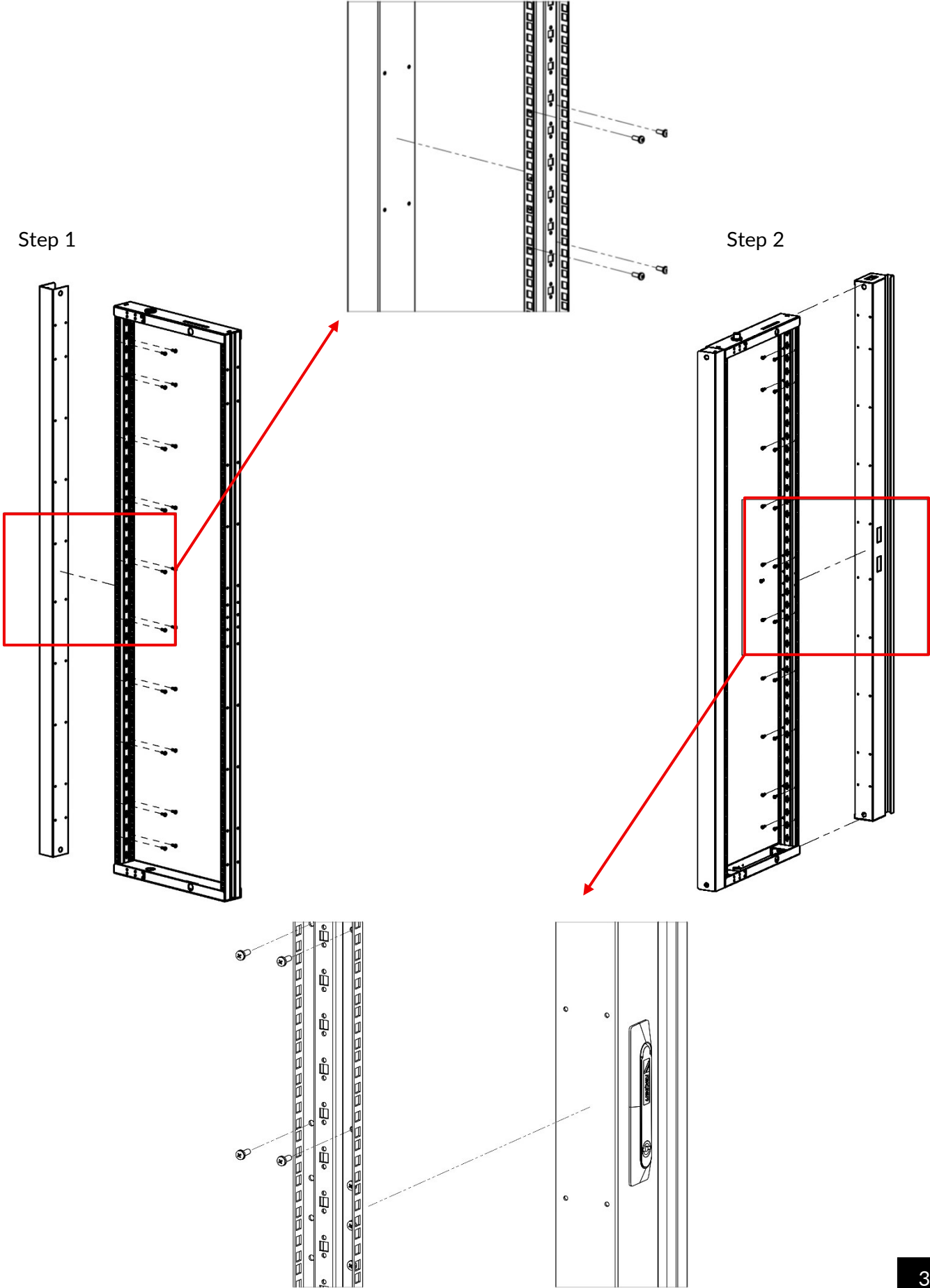

■ Swing Frame 800W SIDE Assembly Model

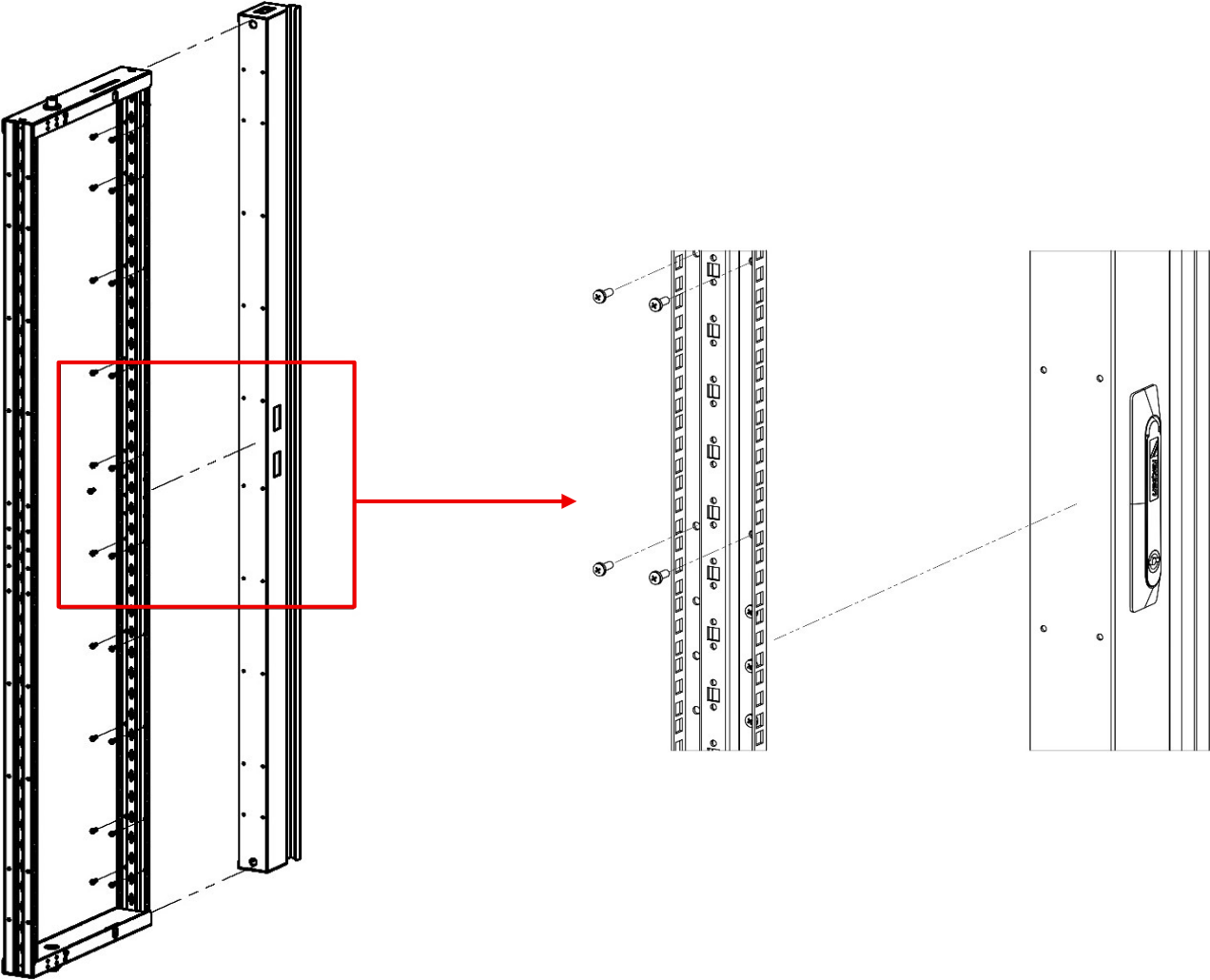

■ INFORMATION OPENS FROM RIGHT AND LEFT

Opens From Right to Left

Opens From Left to Right

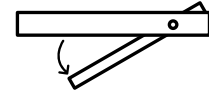
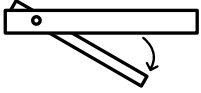

944.008 (Top Rail Part)

944.008 (Bottom Rail Part)



944.008 (Bottom Rail Part)

944.008 (Top Rail Part)



800 mm Width Load Capacity 3500N

944.006 (Top Rail Part)

944.006 (Bottom Rail Part)



944.006 (Bottom Rail Part)

944.006 (Top Rail Part)



600 mm Width Load Capacity 3500N

944.012

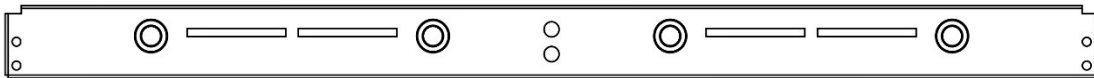

944.012

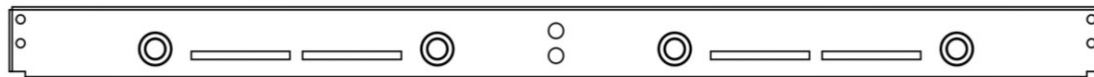

1200 mm Width Load Capacity 1500N

Opens From Right to Left

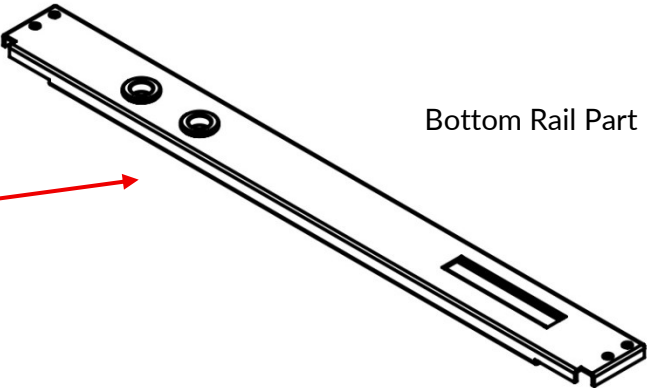
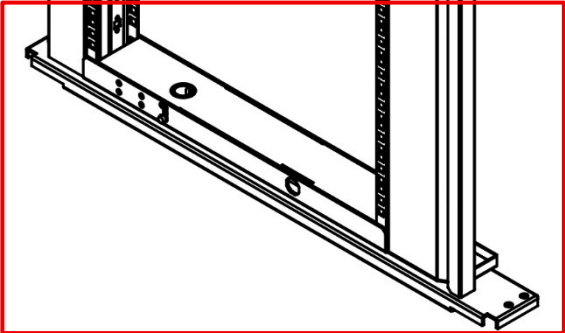
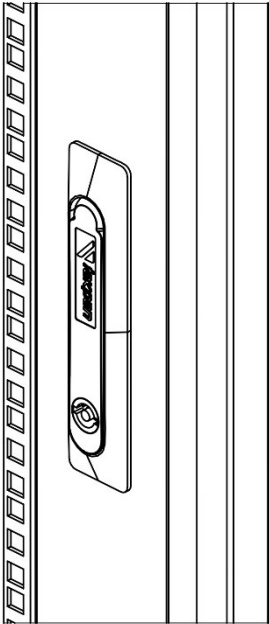
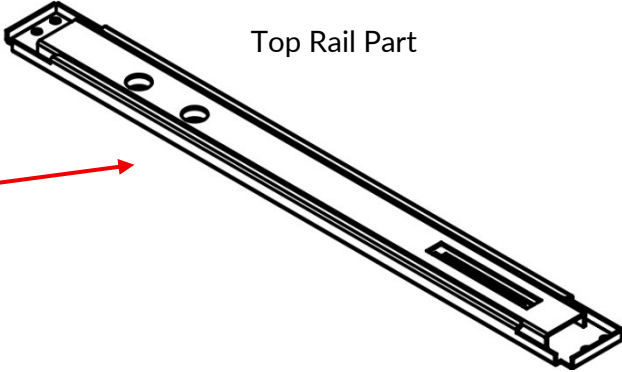
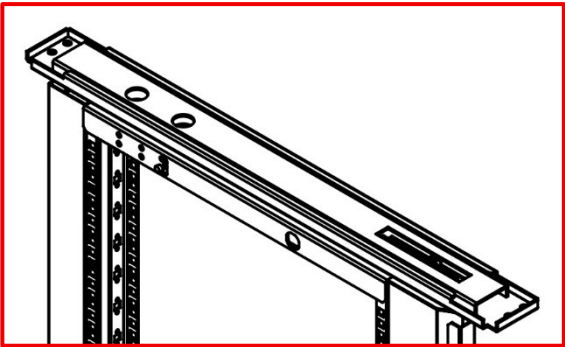

Opens From Left to Right

Bottom Rail Part

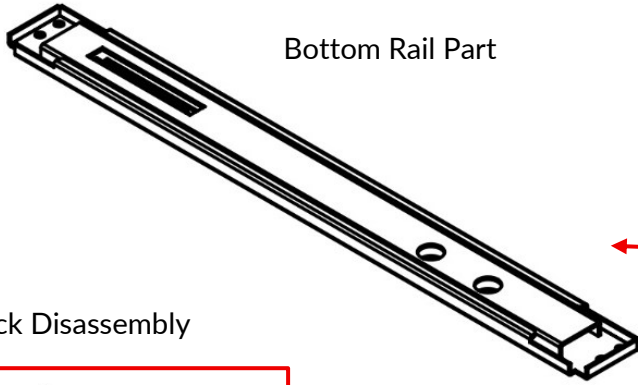

Lock Disassembly

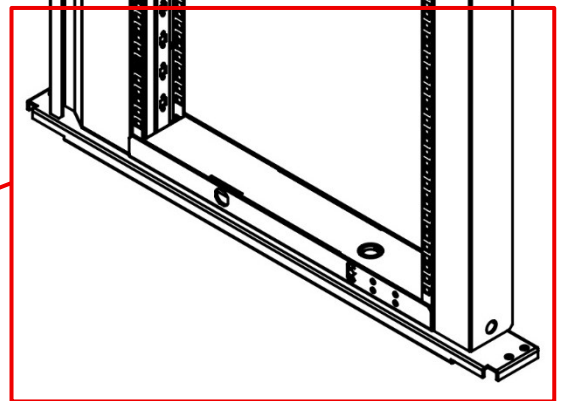
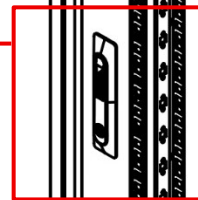
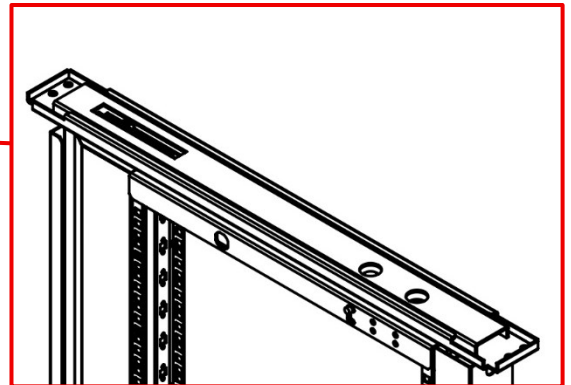
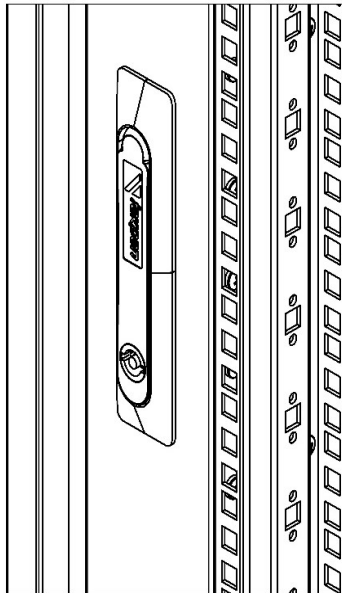
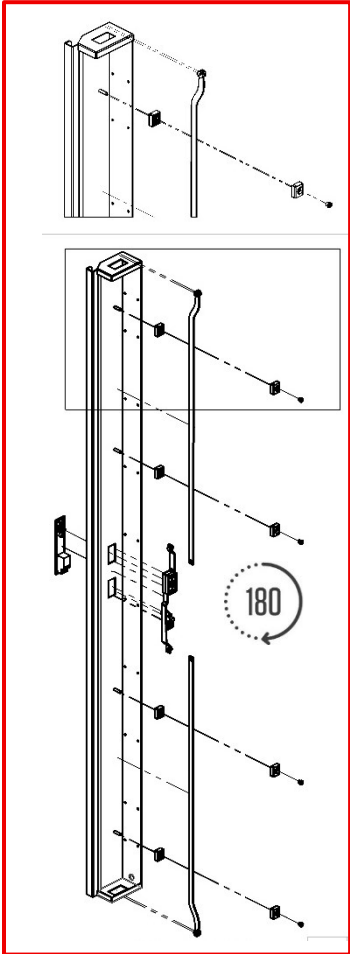

Top Rail Part

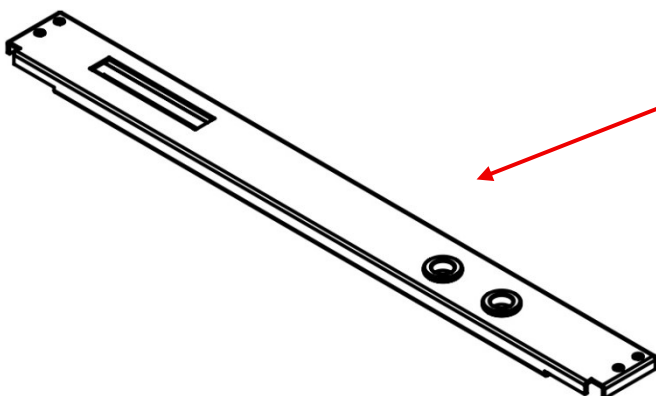

SWING FRAME ASSEMBLY

■ INSTALLATION DEPTH

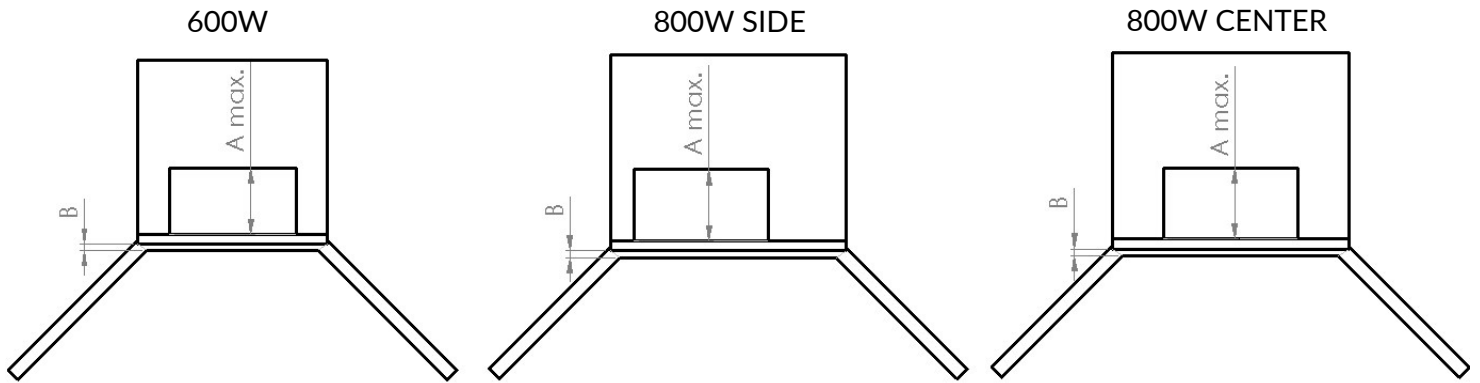

B = The position of the Swing Frame within the Enclosure.

Swing Frame Model	600W	800W SIDE		800W CENTER	
Hinge Type	130	130	180	130	180
Enclosure Depth (mm)	A max.	A max.	A max.	A max.	A max.
400	200	295	260	265	150
500	200	395	360	370	250
600	200	470	440	370	330
800	200	470	440	370	330

■ SWING FRAME RAILS ASSEMBLY FOR TEOS

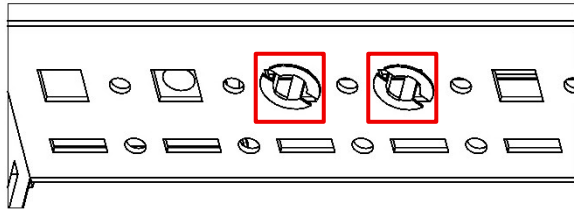

Use these holes for mounting the top and bottom rails parts.

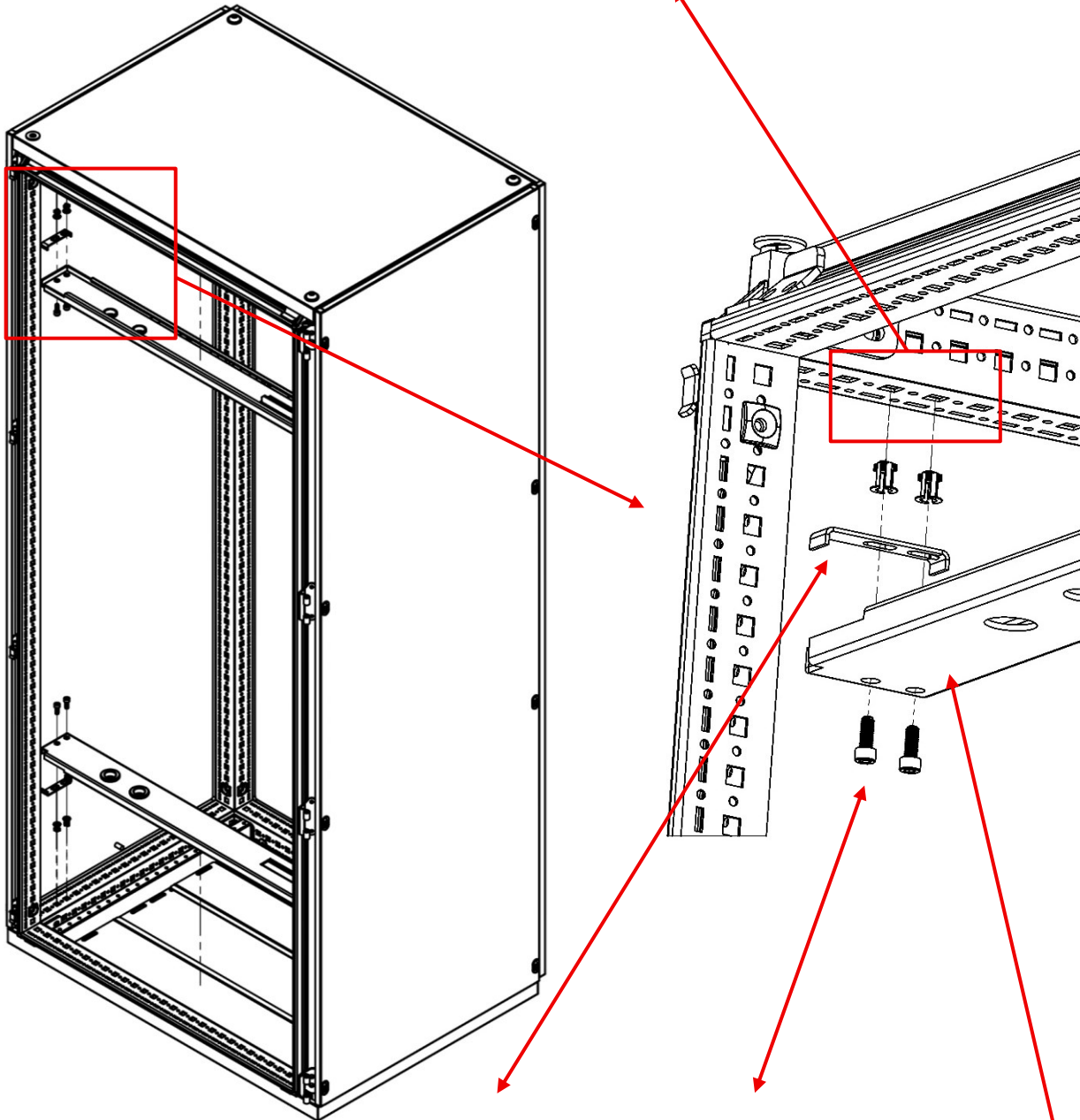

4x Top Bottom Rails Mounting Part

8x Hexagon Socket Head Bolt M6X30

8x Plastic Cage Nut

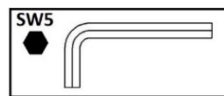
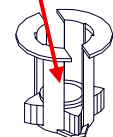
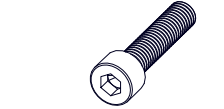
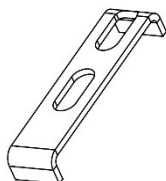

M6 Allen Key

Ma=9,3Nm

■ SWING FRAME RAILS ASSEMBLY FOR NEO

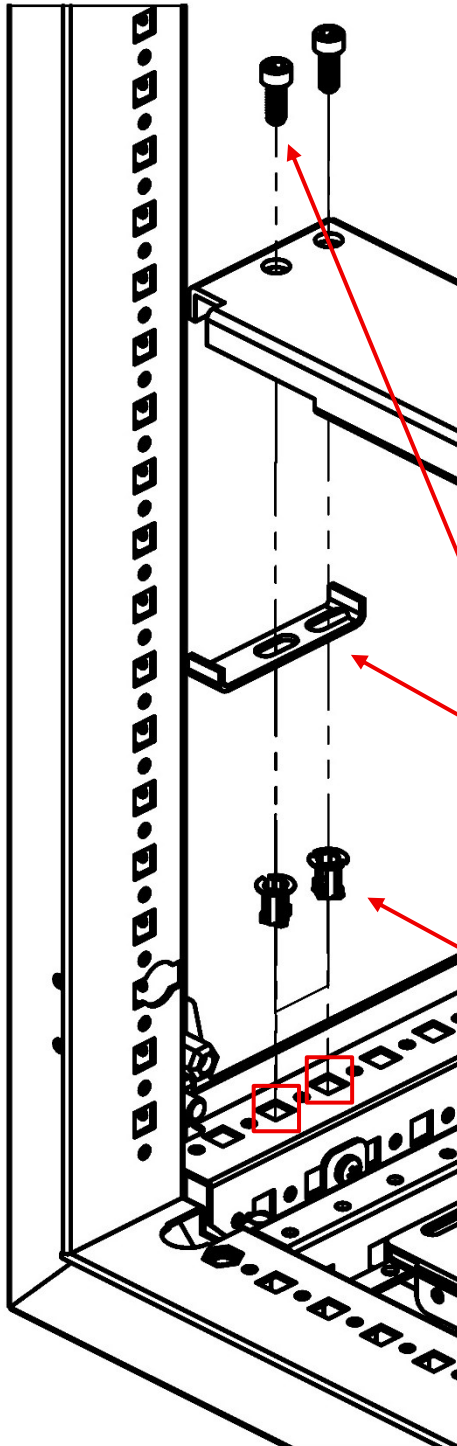

Use these holes for mounting the top and bottom rails parts.

Top Bottom Rails Mounting Part

4x

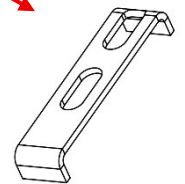

8x

Hexagon Socket Head Bolt M6X30

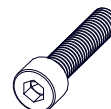

8x

Plastic Cage Nut

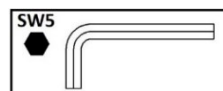
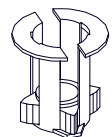

M6 Allen Key

Ma=9,3Nm

■ SWING FRAME RAILS ASSEMBLY FOR 1200W

4x Top Bottom Rails Mounting Part

8x Hexagon Socket Head Bolt M6X30

8x Plastic Cage Nut

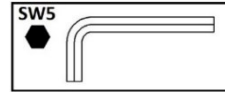
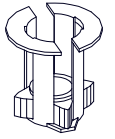
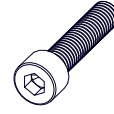
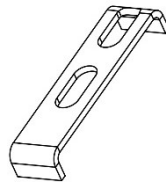
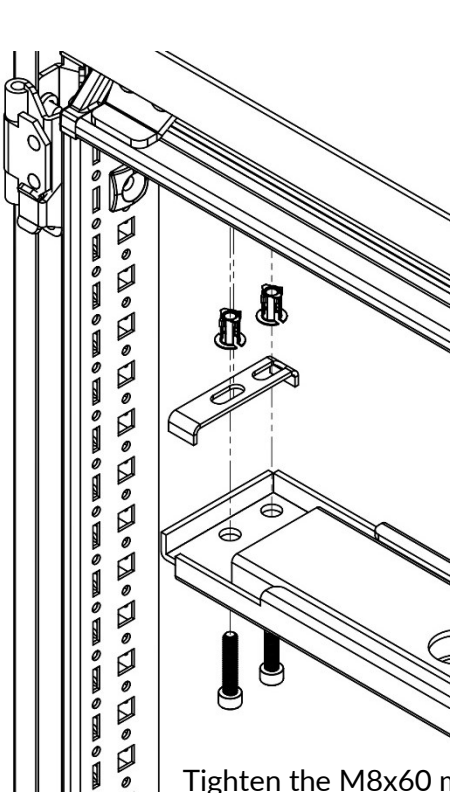

M6 Allen Key

Ma=9,3Nm

Tighten the M8x60 mm hexagon socket screws with rivet nuts until the tip of the screws touches the surface.

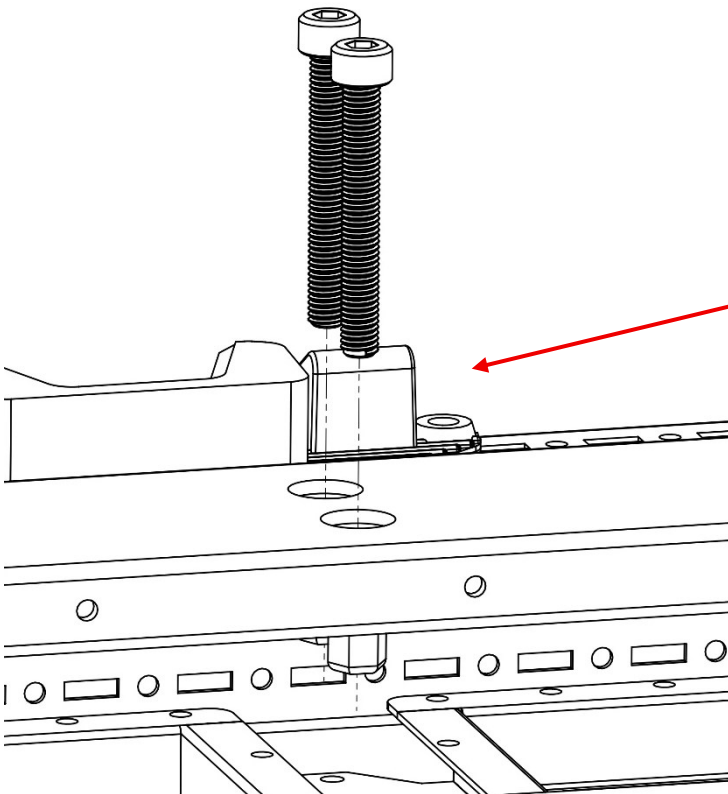
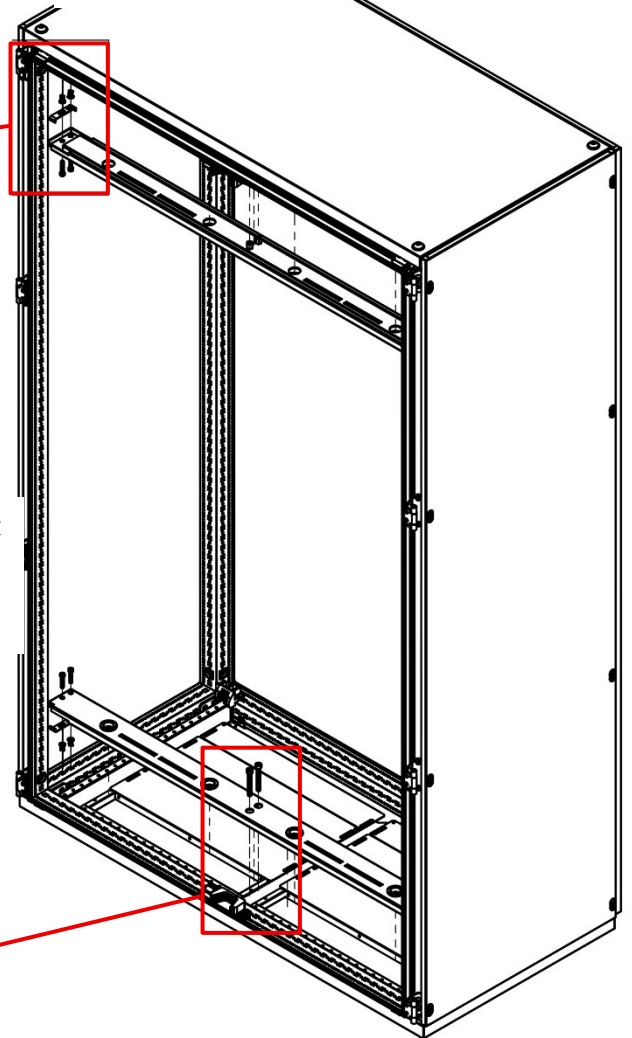

2x Hexagon Socket Head Bolt M8X60

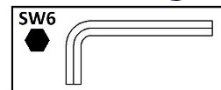

M8 Allen Key

Ma=22,5Nm

■ SWING FRAME ASSEMBLY (130 ANGLE)

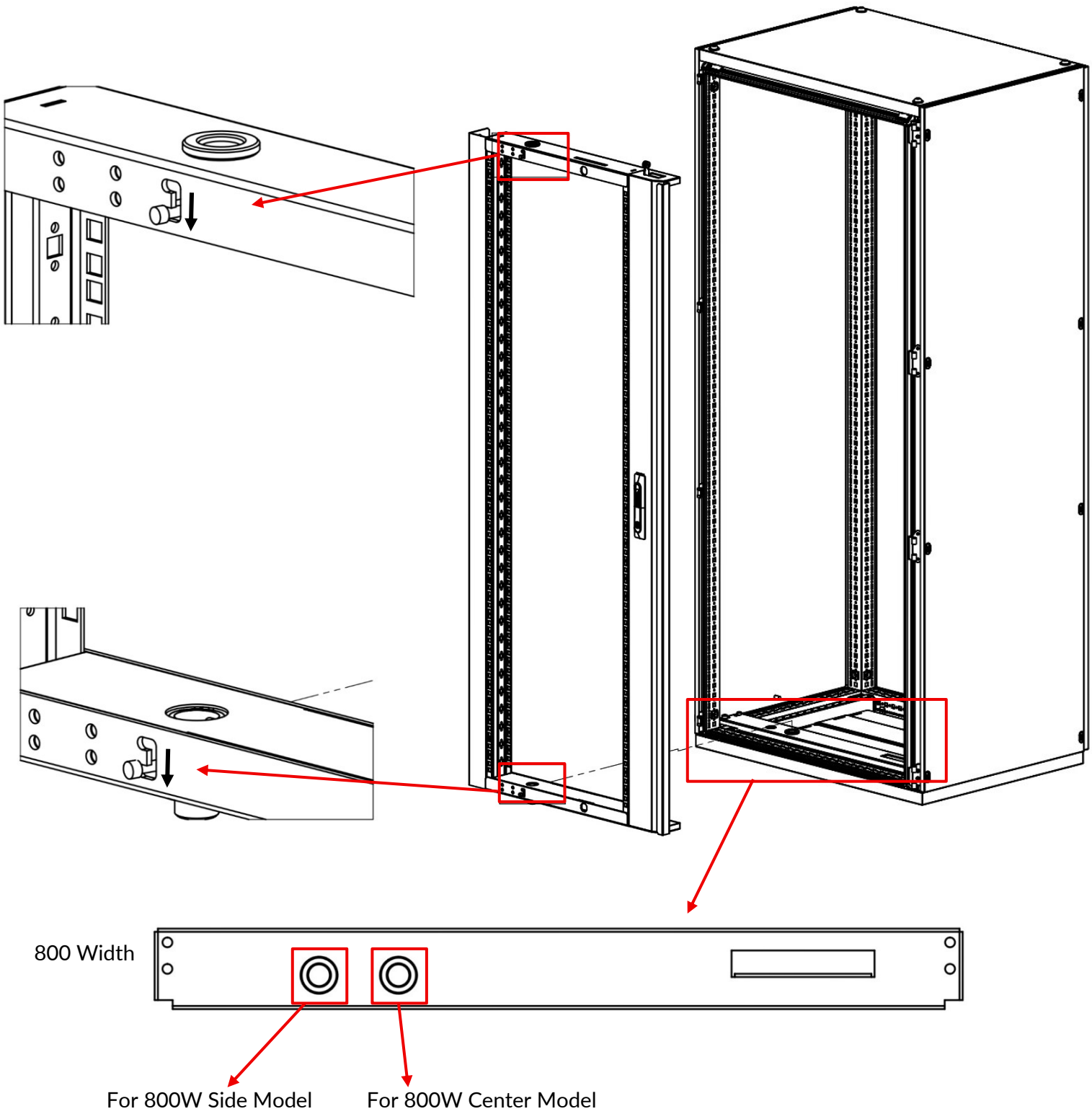

■ SWING FRAME ASSEMBLY (130° ANGLE)

Then move it to the open position.

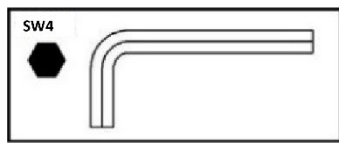
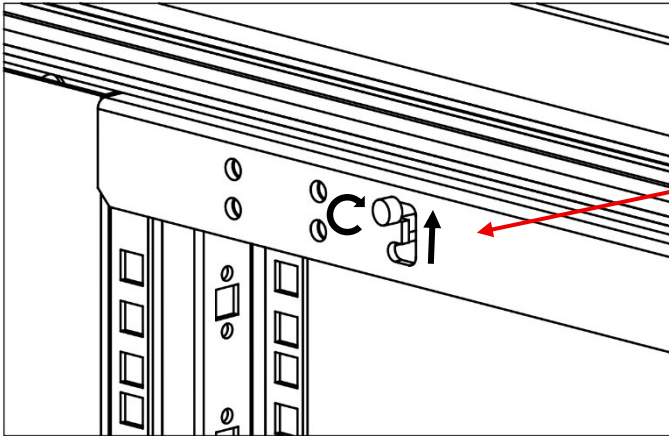

Tighten the screws firmly.

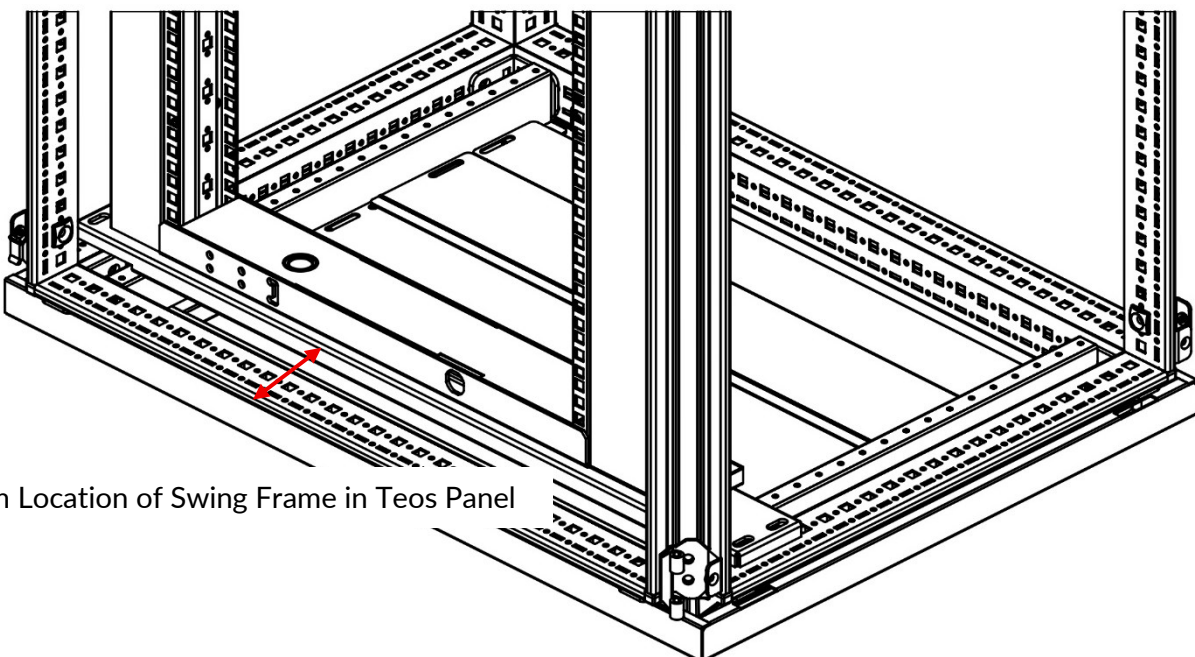
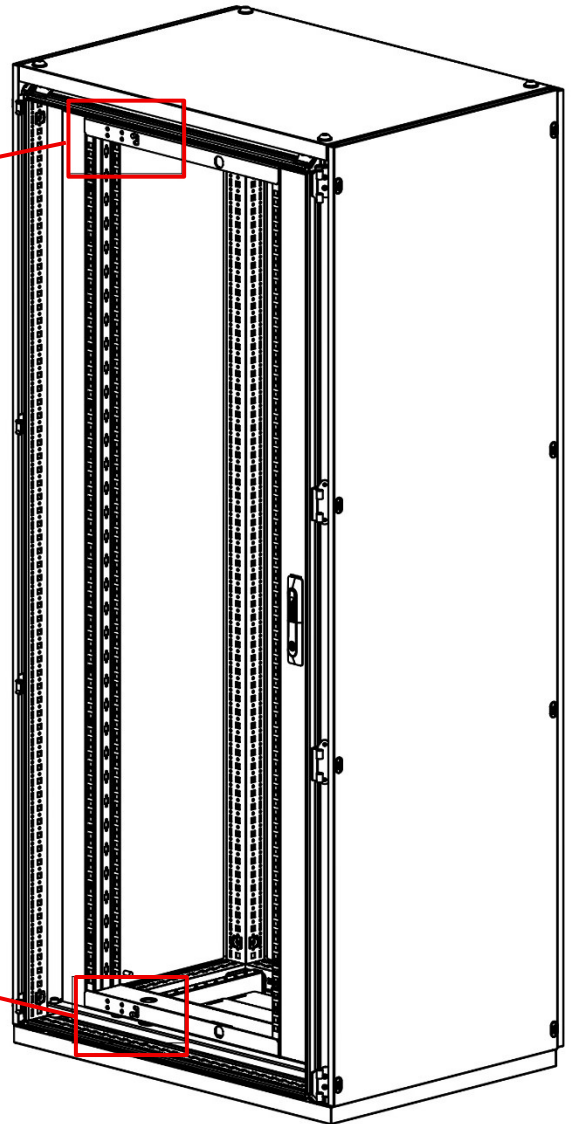
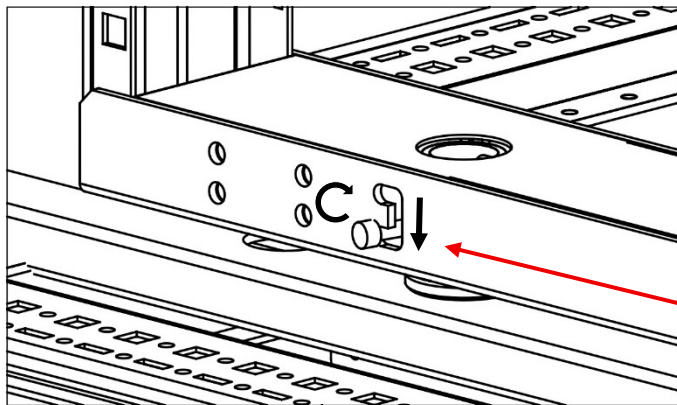

77 mm Location of Swing Frame in Teos Panel

■ SWING FRAME STOPPER ASSEMBLY

600W

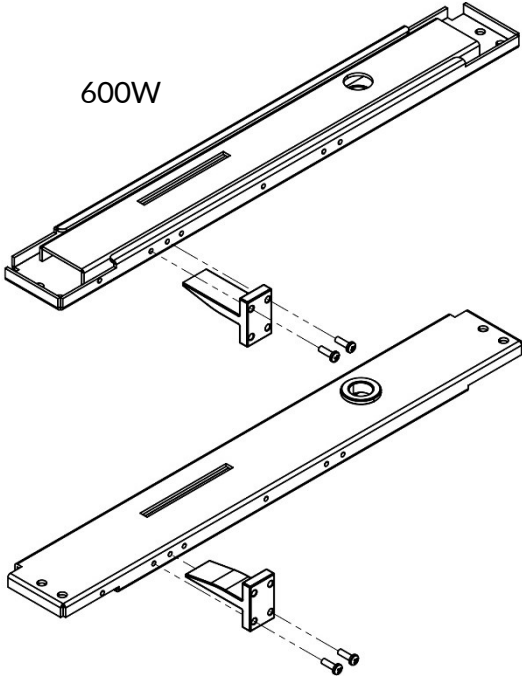

800W CENTER

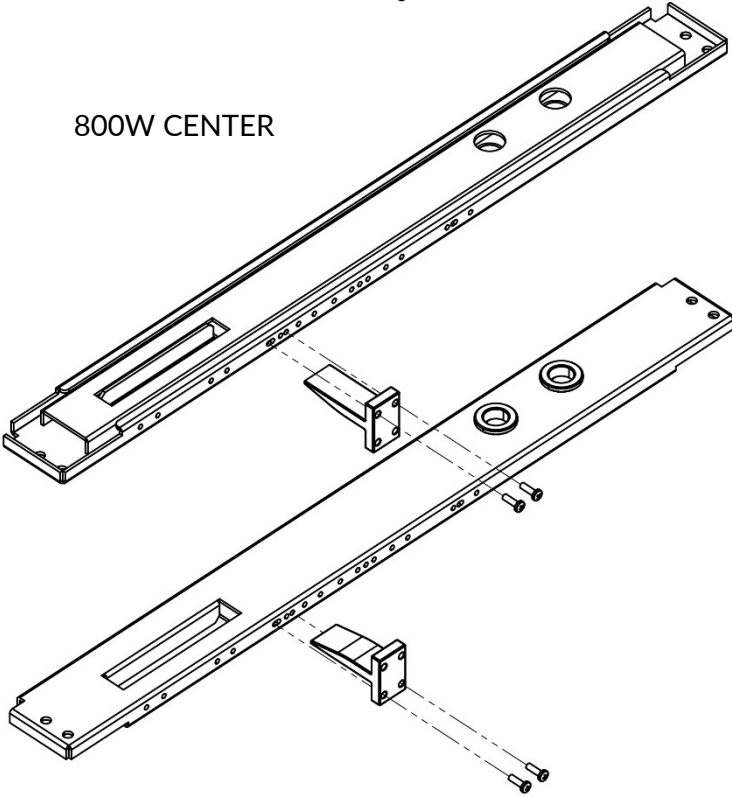

800W CENTER
WITH DOOR
HANDLE

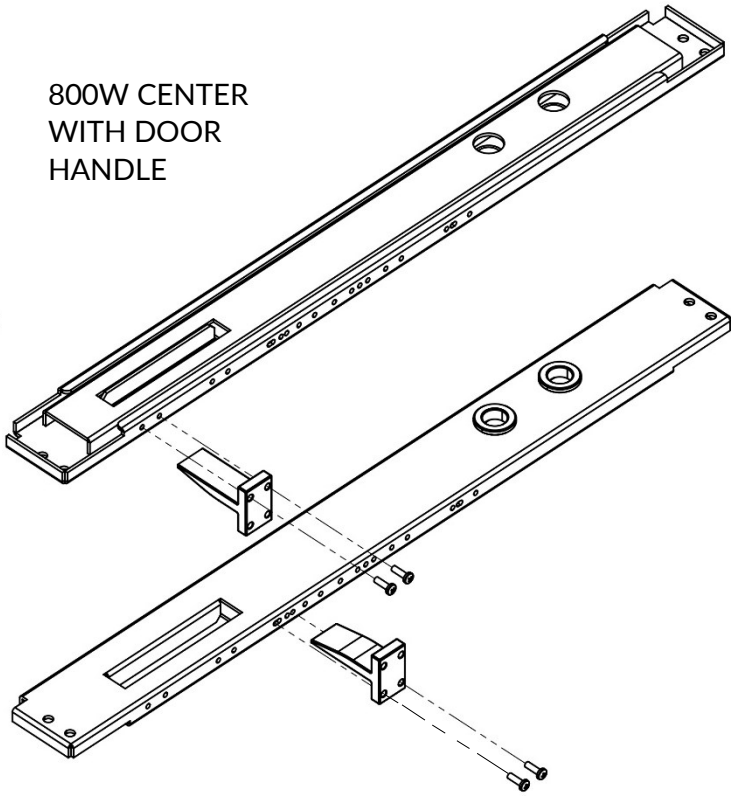

SWING FRAME ASSEMBLY

800W SIDE

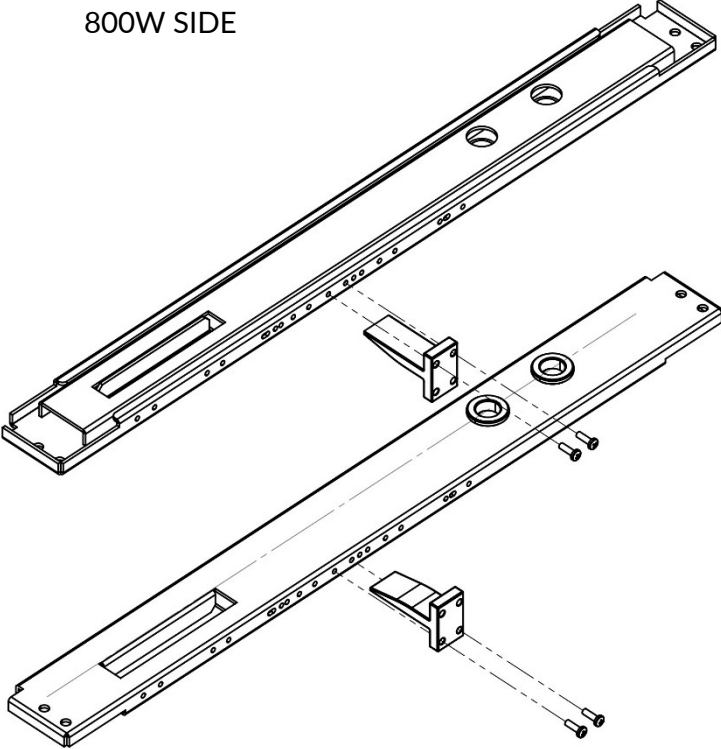

800W SIDE
WITH DOOR
HOLDER

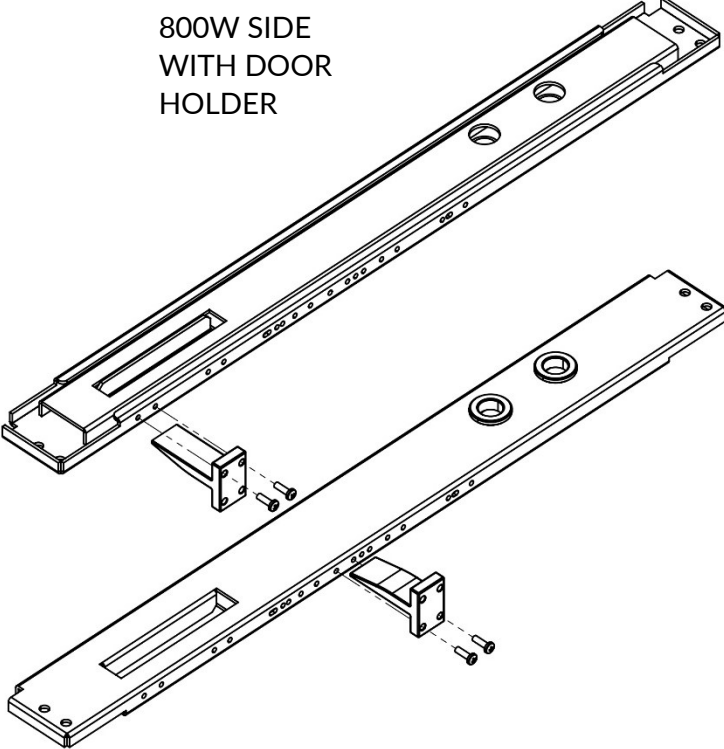

1200W

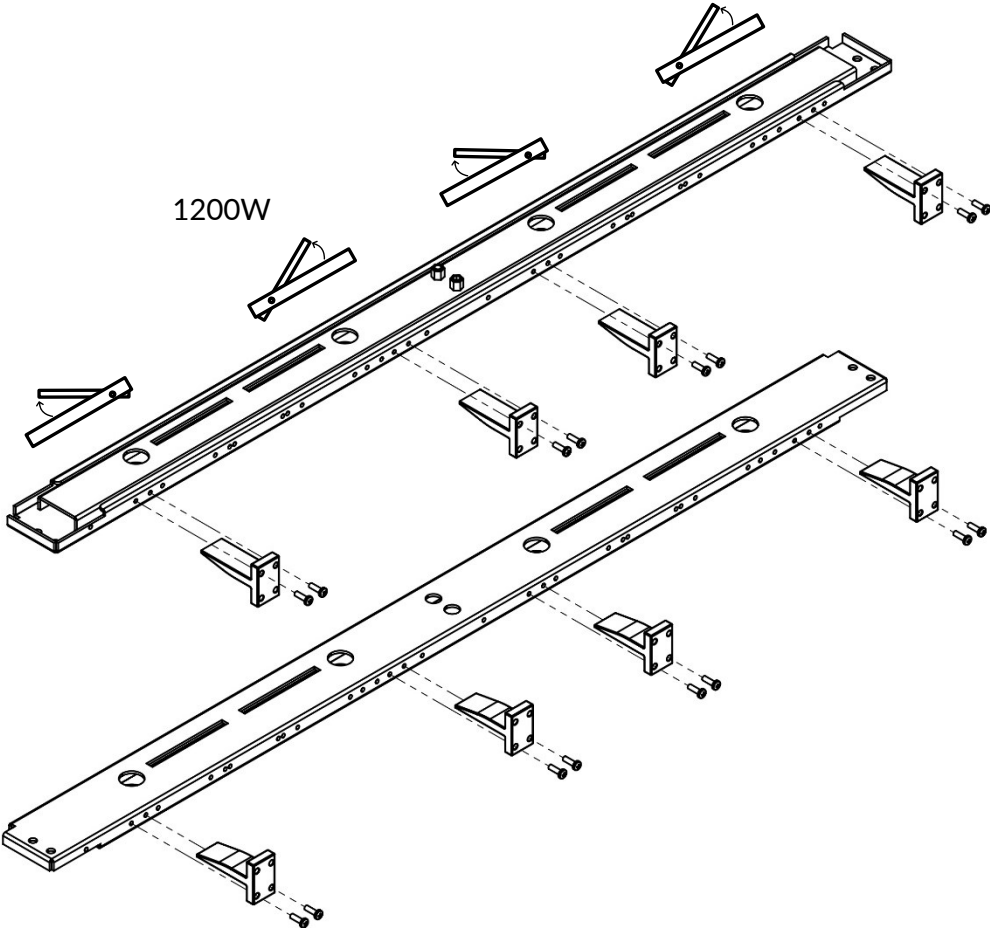

ACCESSORIES

Long type is for 180 Angle

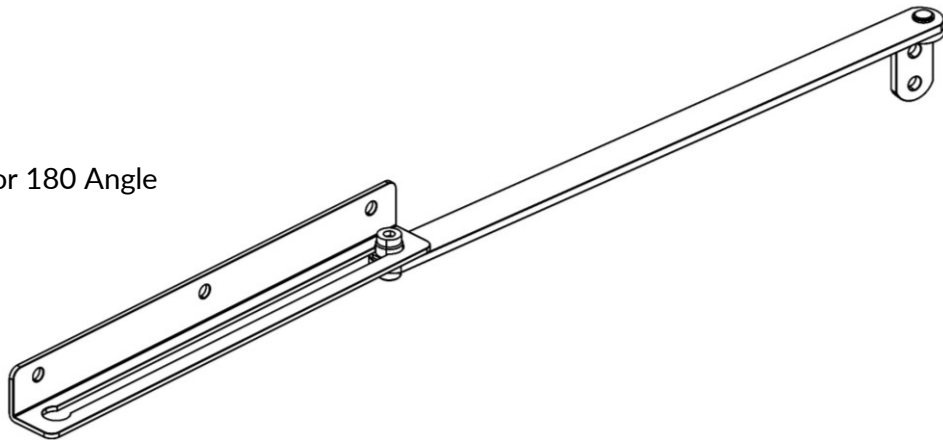

Short type is for 130 Angle

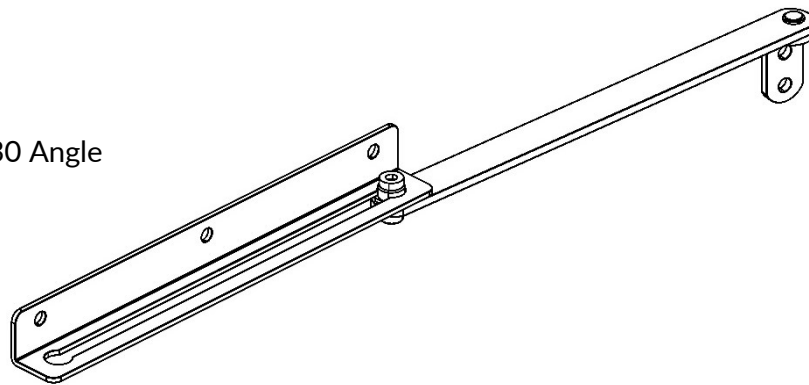

944.300 180 Angle hinge kit

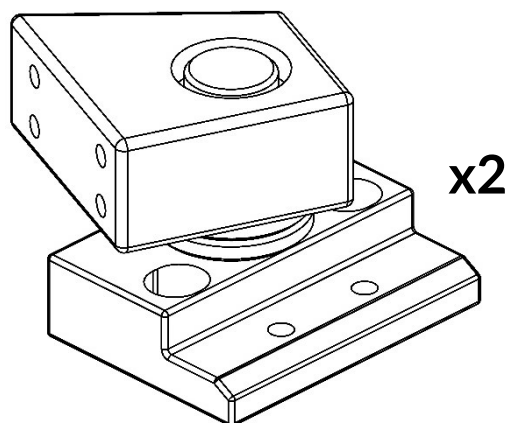

180 ANGLE HINGE KIT FOR 800W CENTER MODEL

For Teos

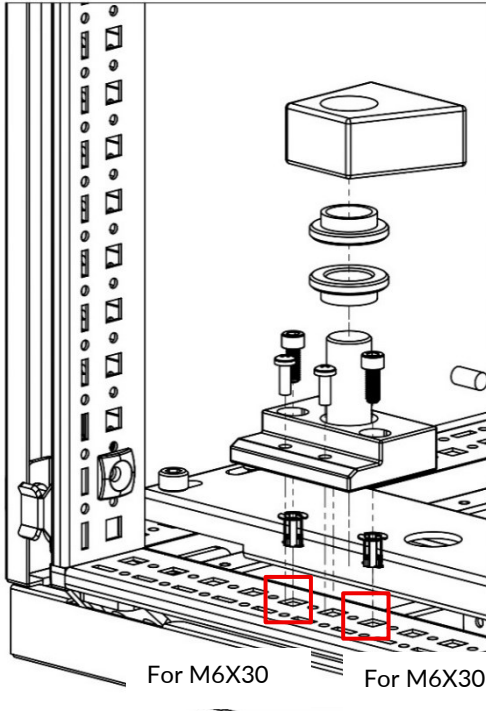

Load Capacity
1500N

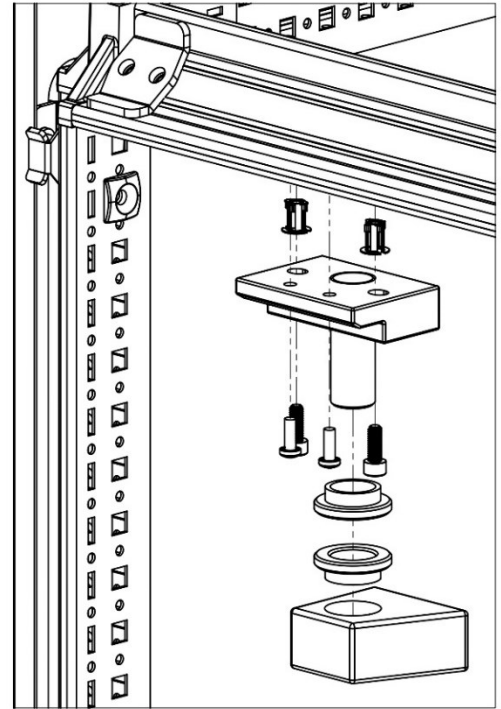

For Neo

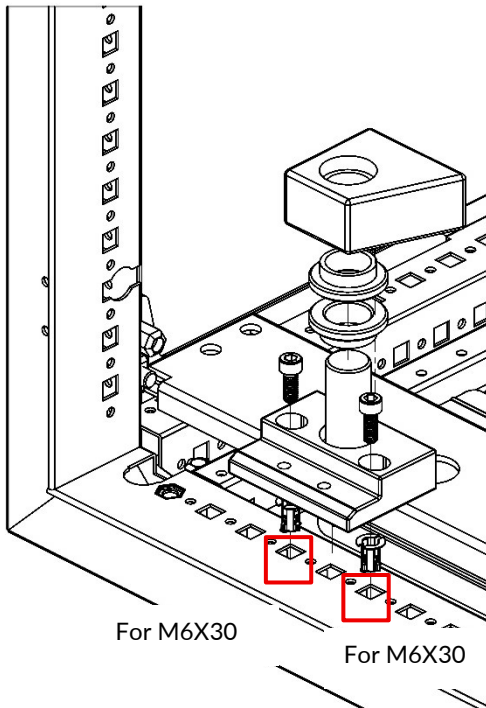

Load Capacity
1500N

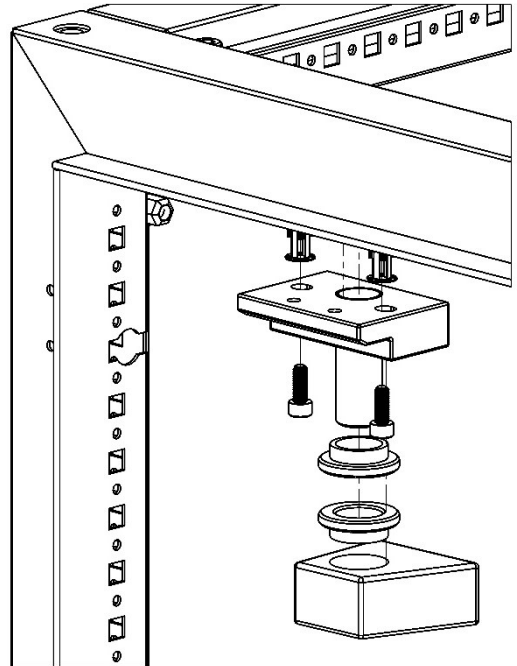

Pan Head
Screw

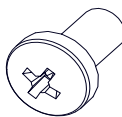

4x Hexagon Socket
Head Bolt M6X30



4x Plastic Cage
Nut

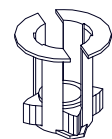

Cross

Ma=5,5Nm

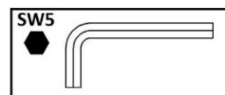

M6 Allen Key

Ma=9,3Nm

180 ANGLE HINGE KIT FOR 800W SIDE MODEL

For Teos

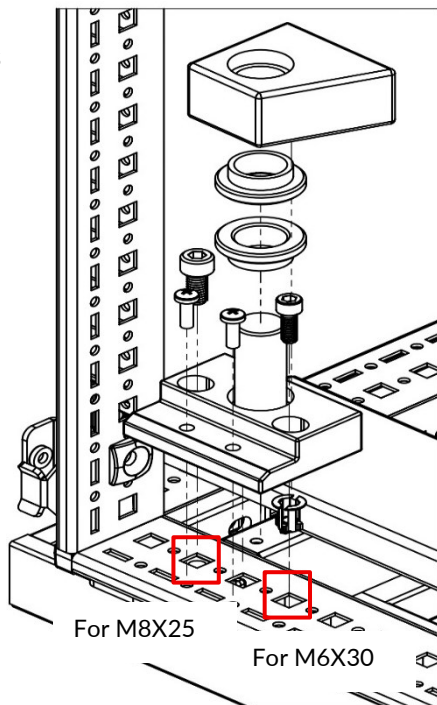

Load Capacity
1500N

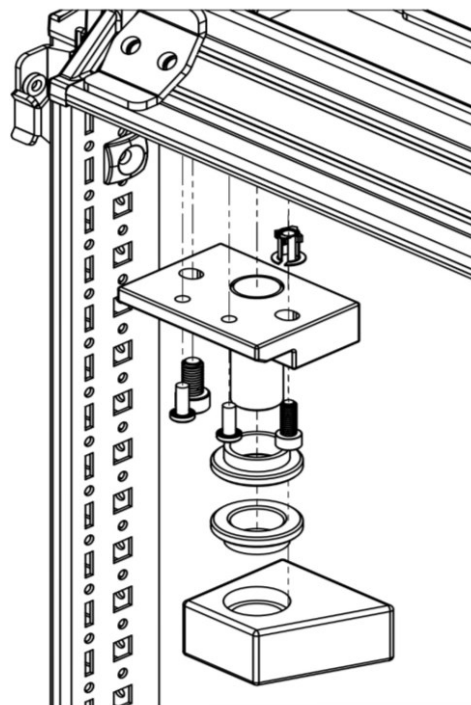

For Neo

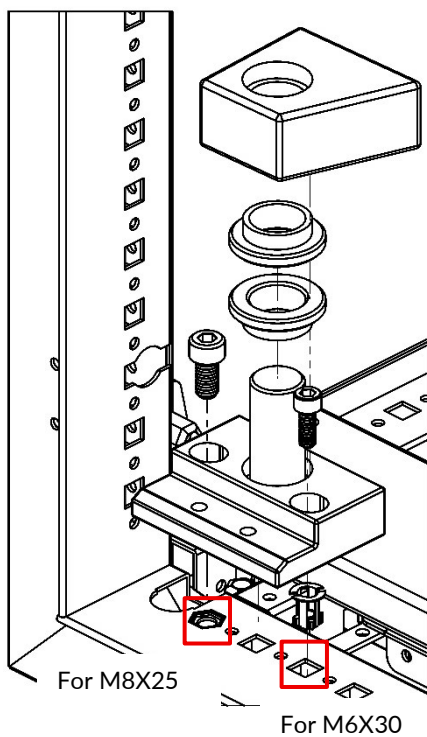

Load Capacity
1500N

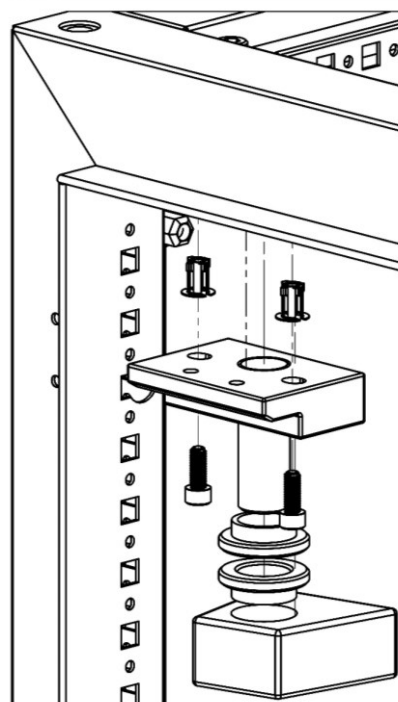

4x Pan Head Screw

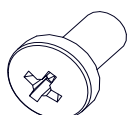

2x Hexagon Socket Head Bolt M6X30



2x Hexagon Socket Head Bolt M8X25

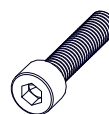

4x Plastic Cage Nut



Cross

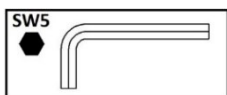

M6 Allen Key

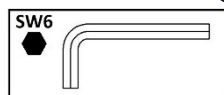

M8 Allen Key

Ma=5,5Nm

Ma=9,3Nm

Ma=22,5Nm

■ SWING FRAME ASSEMBLY (180 ANGLE)

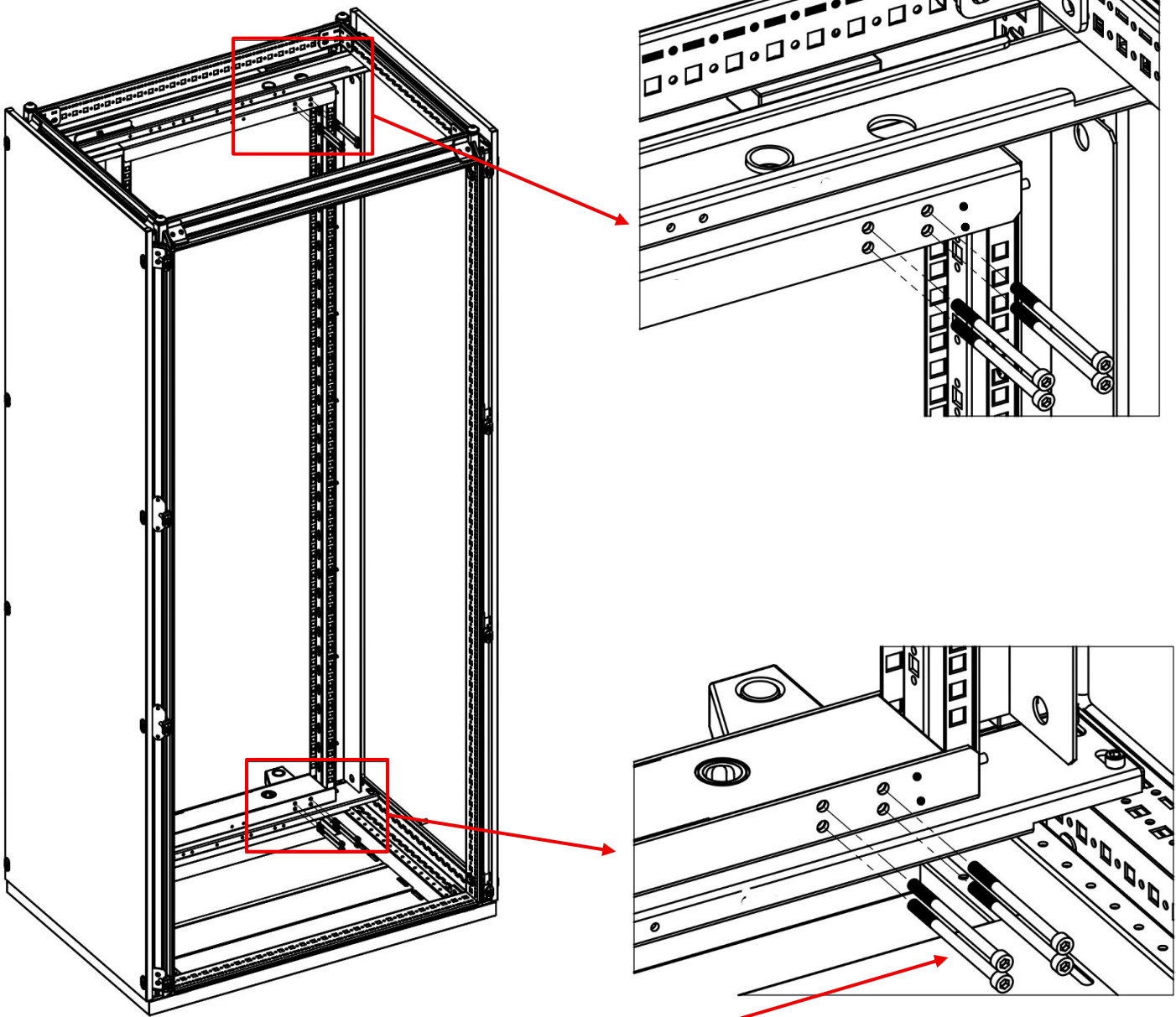

8x Hexagon Socket
Head Bolt M6X90

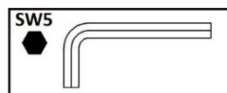
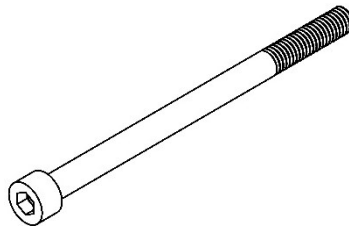

M6 Allen Key

Ma=9,3Nm

■ DOOR HOLDER PART ASSEMBLY FOR SHORT TYPE

130 Angle For 800W Center

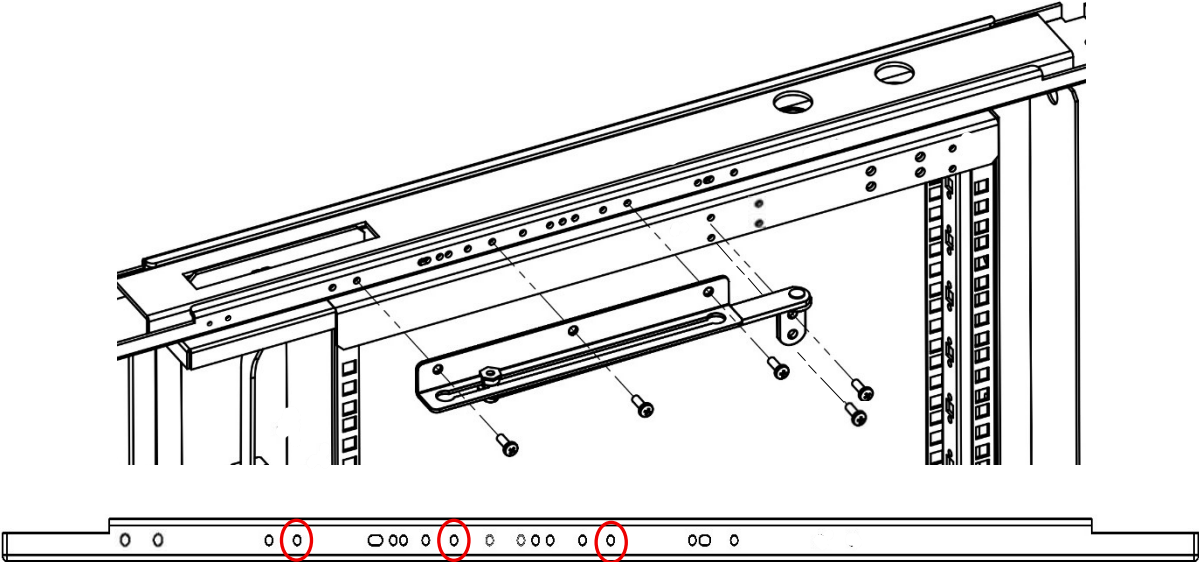

130 Angle For 800W Side

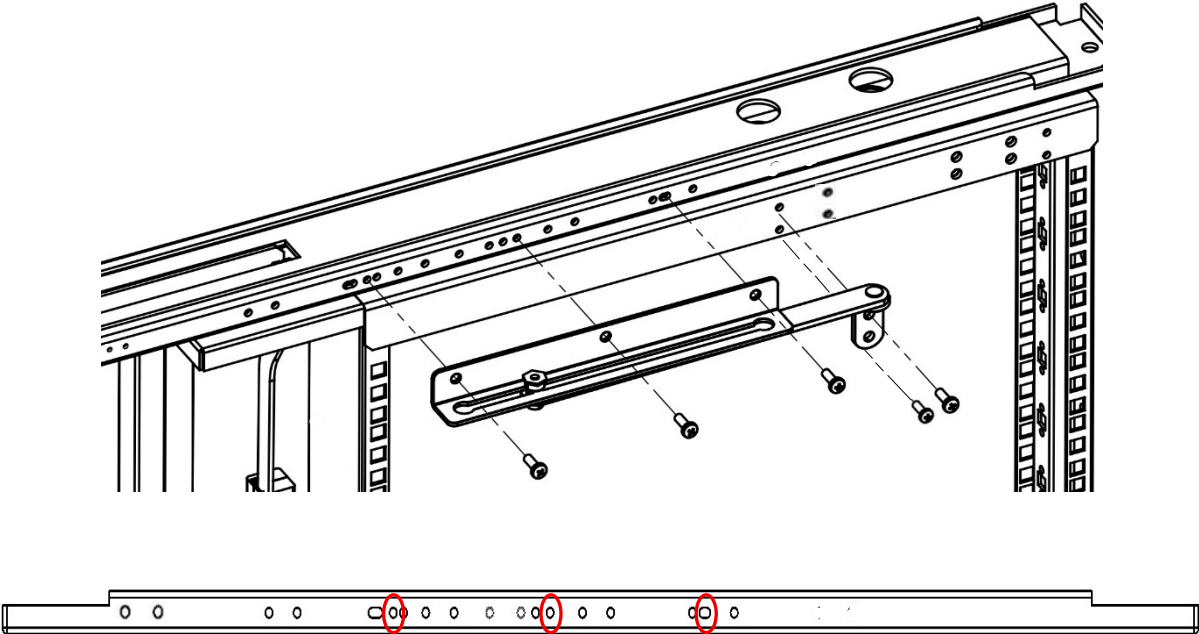

DOOR HOLDER PART ASSEMBLY FOR LONG TYPE

180 Angle For 800W Center

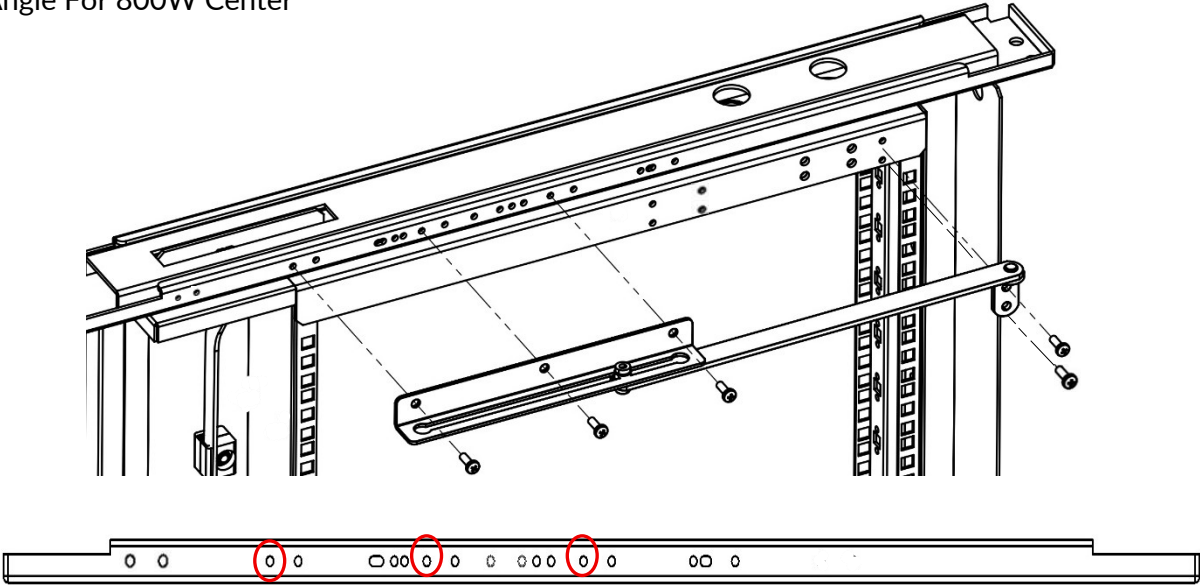

180 Angle For 800W Side

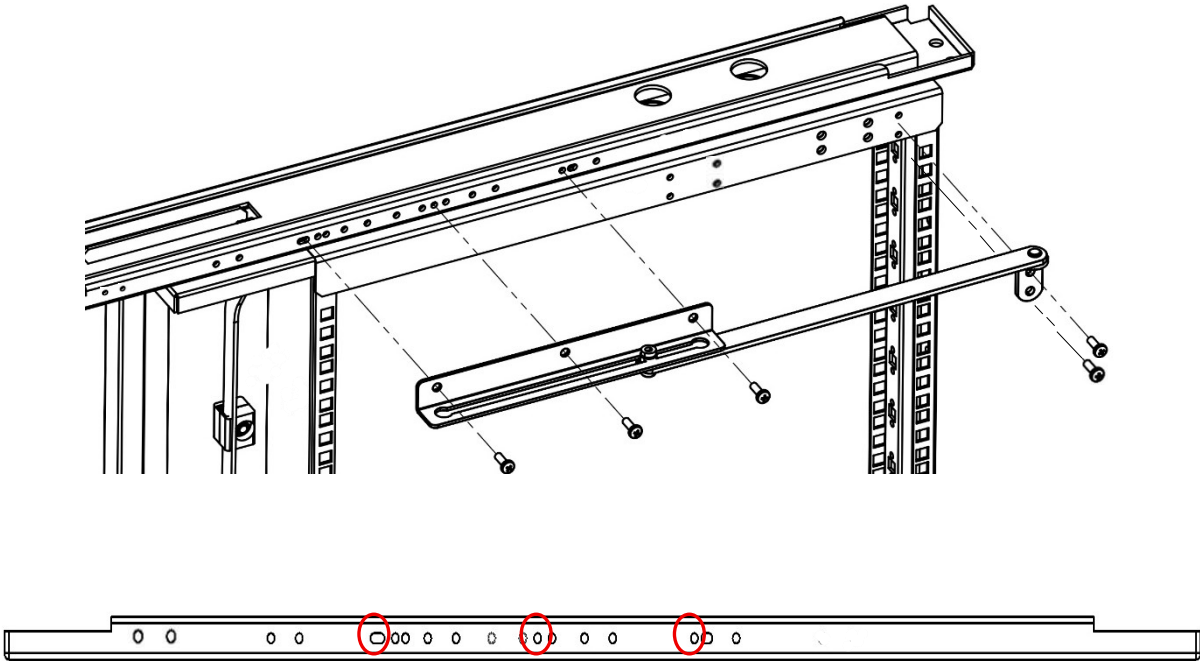

1200W DOOR HOLDER PART ASSEMBLY FOR SHORT TYPE

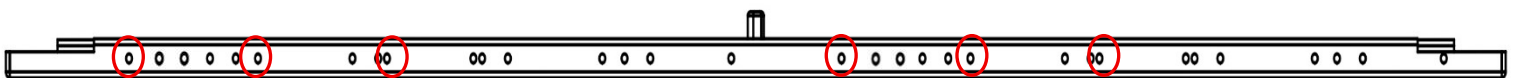
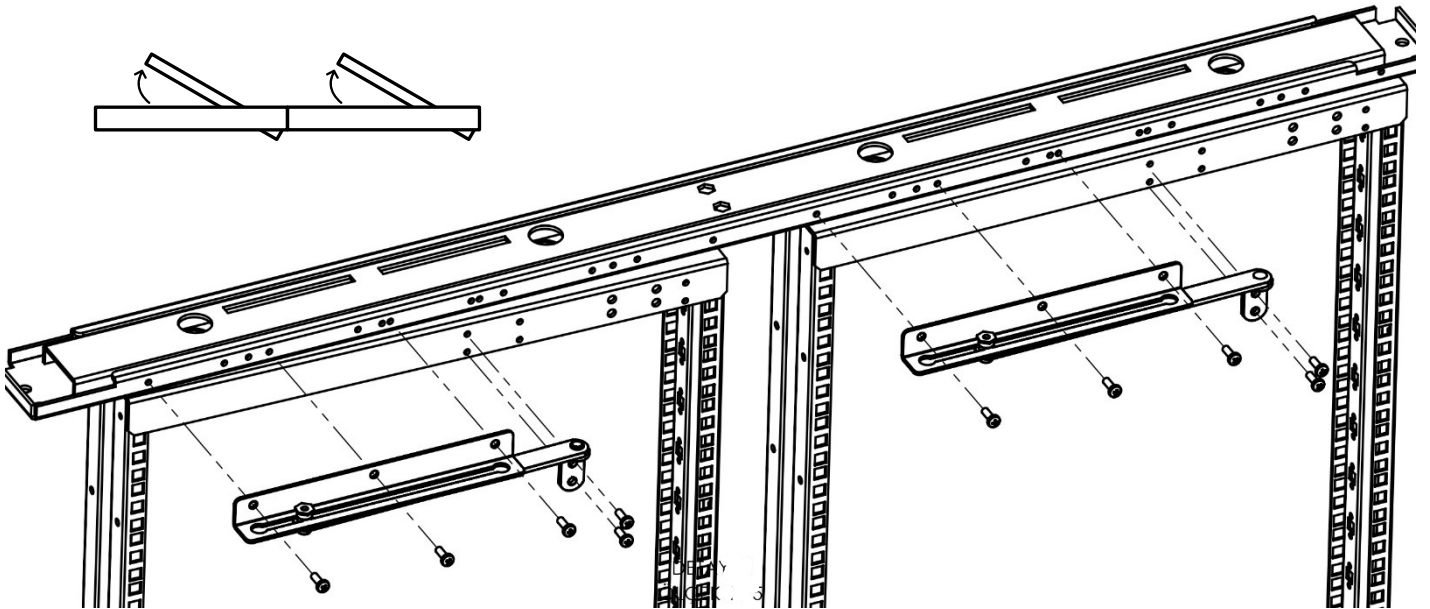
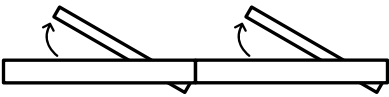
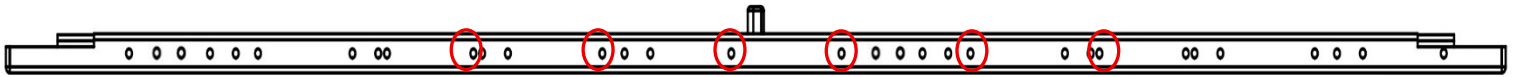
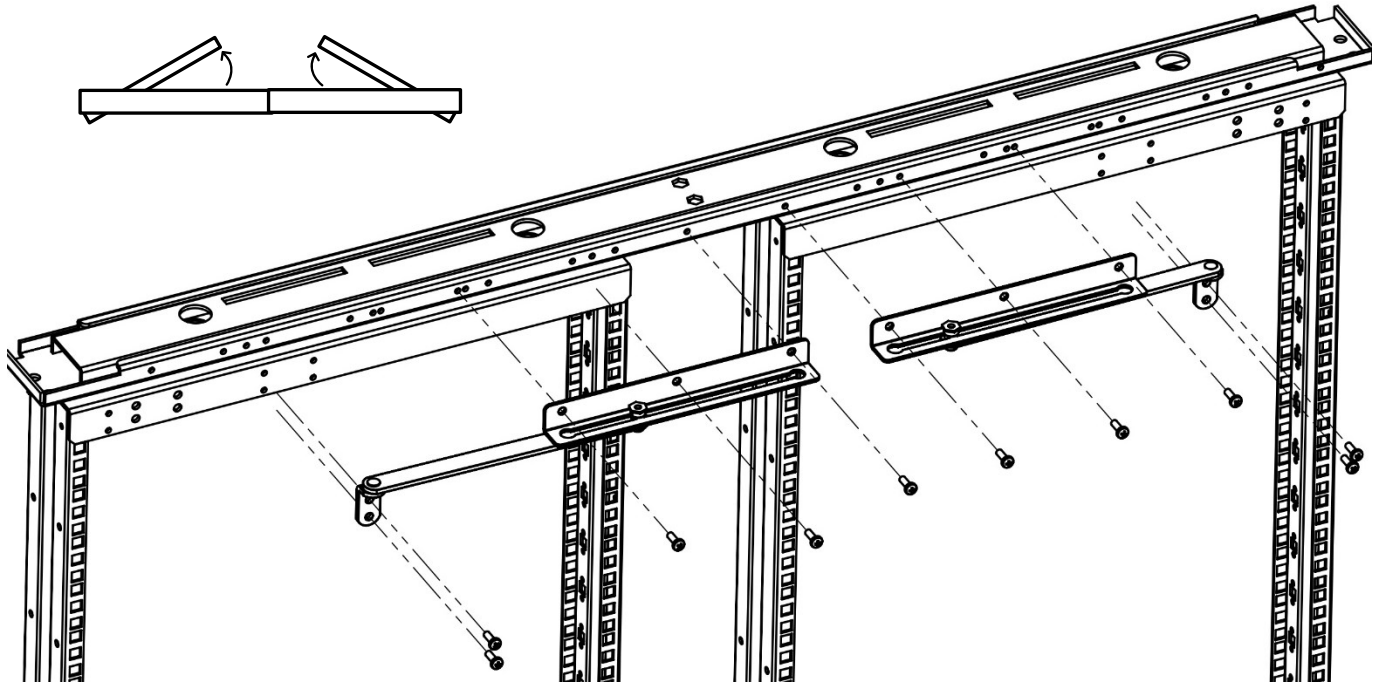
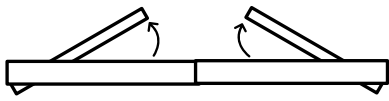

■ 1200W DOOR HOLDER PART ASSEMBLY FOR SHORT TYPE

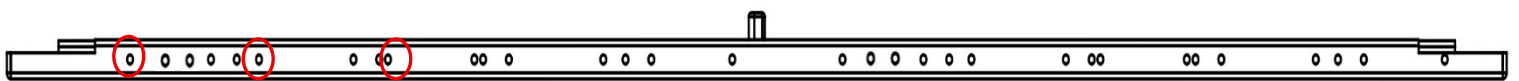
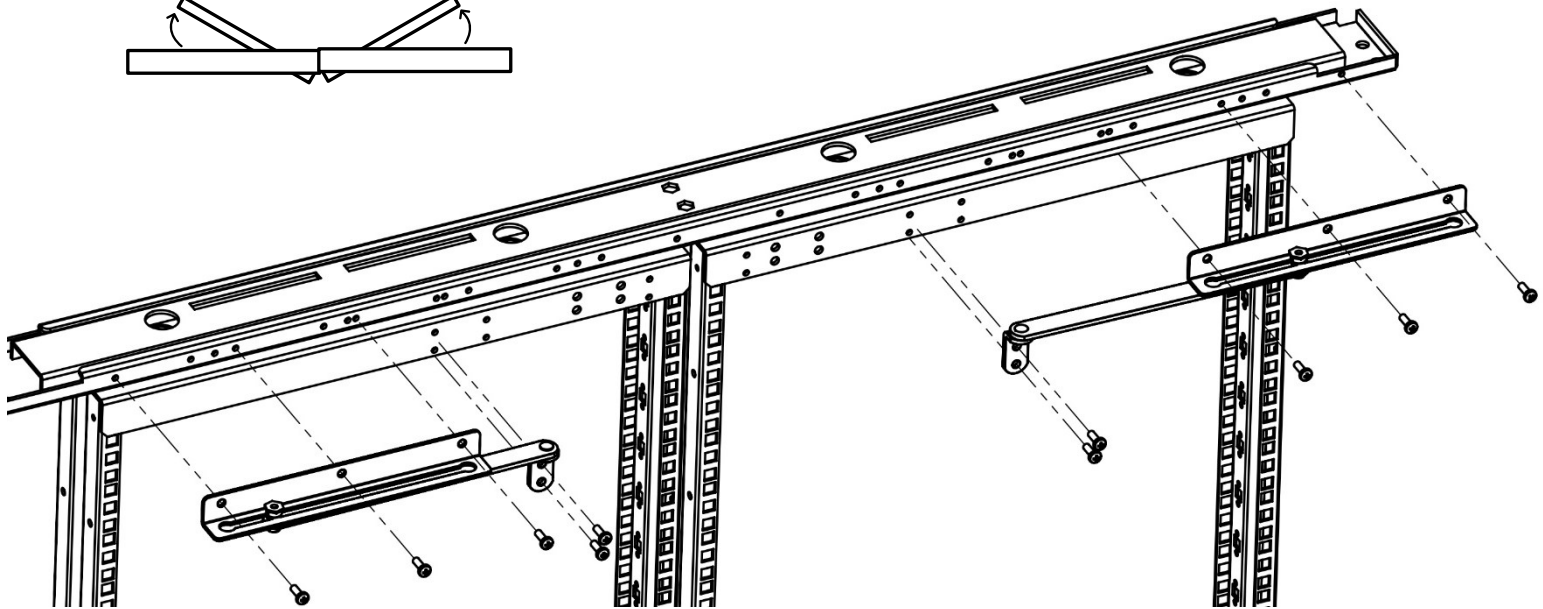
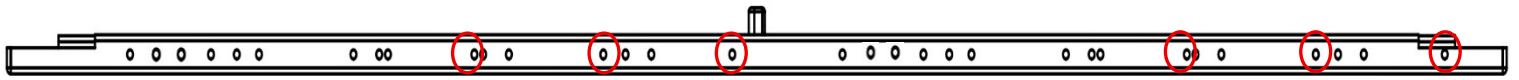
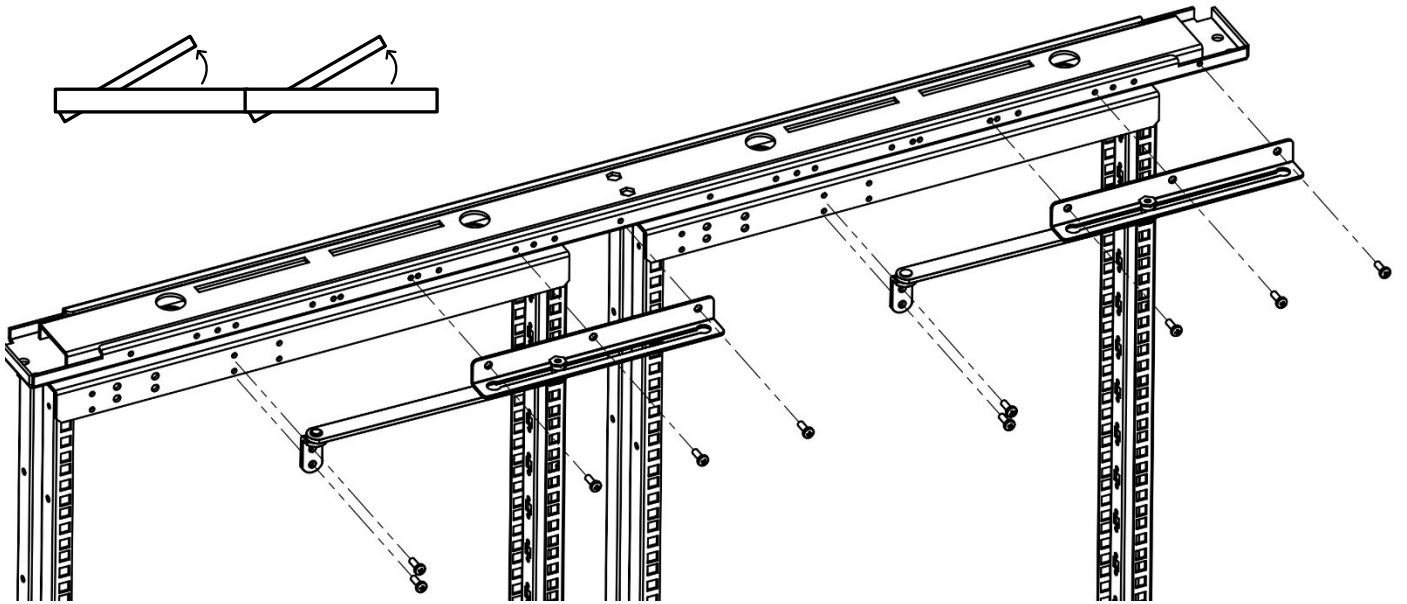
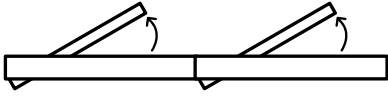

SWING FRAME ASSEMBLY

EARTHING

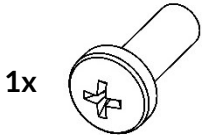
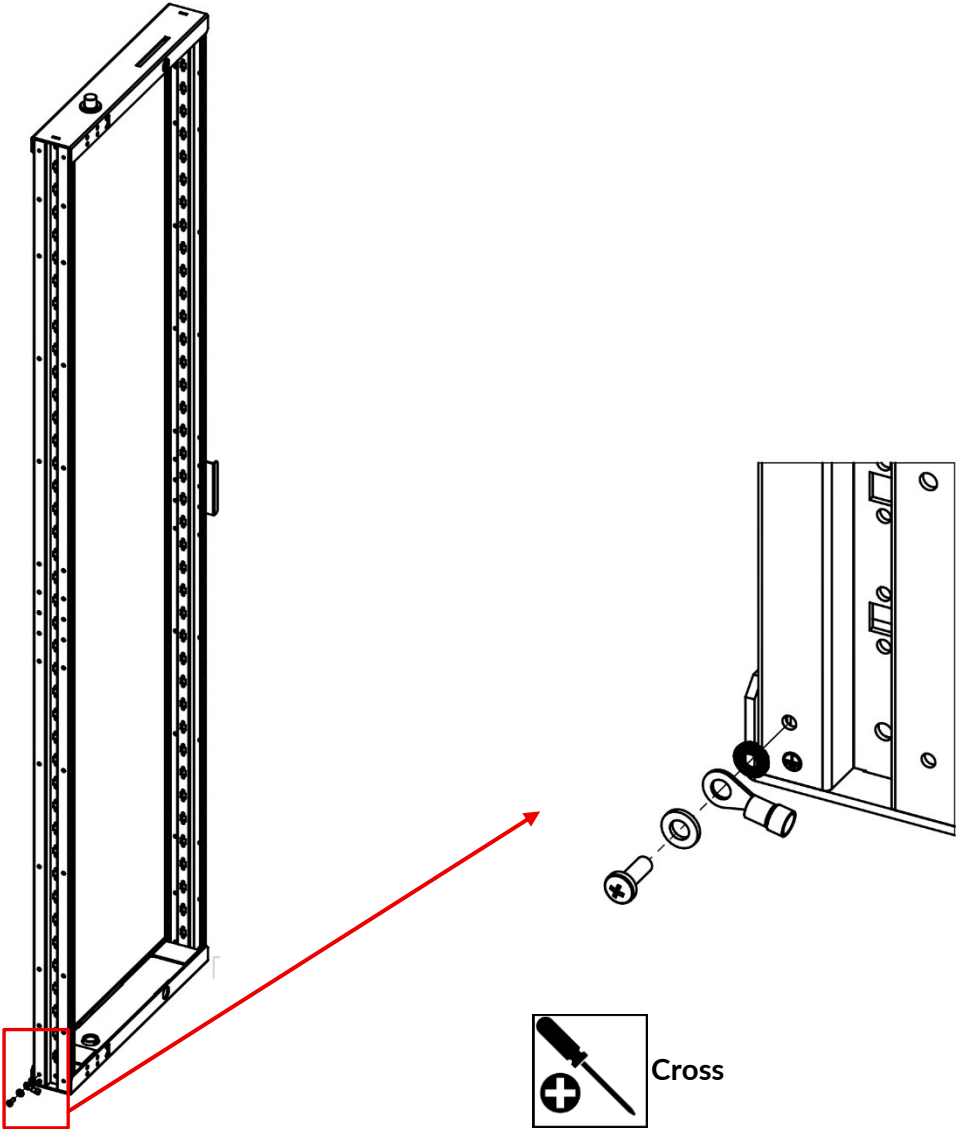

**M5X14 TAPTITE
SCREW**



**M5 FLAT
WASHERM5 FLAT**



**M5 CONICAL TAB
WASHERWASHER**



EARTHING LABEL